

Morgana **ElectroCreaser 52**

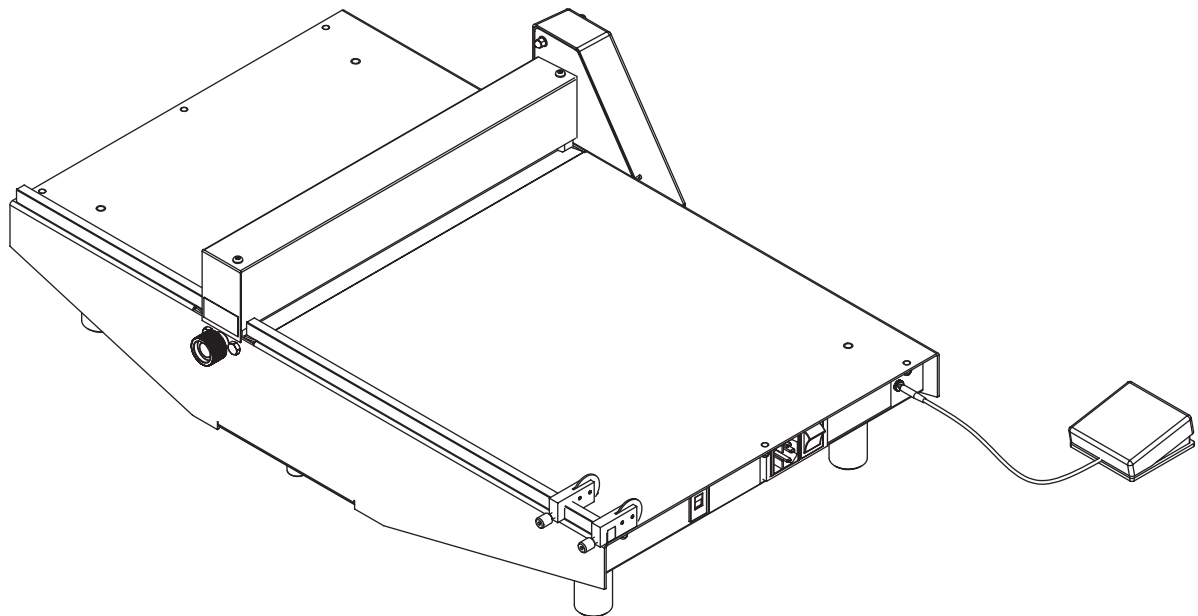

Morgana Systems Limited United Kingdom
Telephone: (01908) 608888 Facsimile: (01908) 692399
Website: W W W .Morgana.co.uk

ISSUE 4

SEPTEMBER 2008

47 - 263

SAFETY Do's & Don'ts	Page 3
LABELED DRAWING	Page 4
OPERATING INSTRUCTIONS	Page 4
ILLUSTRATED PARTS LIST	Pages 5 to 9
WIRING DIAGRAM	Page 10
ROUTINE MAINTENANCE	Page 11
RECOMMENDED SPARES LIST	Page 12

Specification

Overall Dimensions:-	Length	780mm
	Width	640mm
	Height	218mm
	Weight	27.5Kgs
Maximum Crease:- (To Backstop)	Length	520mm
	Width	520mm
Minimum Crease:- (To Backstop)	Length	35mm
Power Requirement:-	1 phase 200 / 253v 50 / 60Hz	
	1 phase 100 / 125v 60Hz	

Safety Do's & Don'ts

Do - read this operator manual fully before operating the machine.

Do - operate with the designated AC current only. Use an exclusive outlet, as overloading may cause fire or an electric shock.

Do - install the power cord out of the way to avoid a tripping hazard.

Do - beware of finger traps when replacing roller cassette and fold plates.

Do not - install the machine in an unstable place such that it tilts or shakes.

Do not - unplug the plug or unplug the power cord from the outlet with a wet hand, this can cause an electric shock.

Do not - unscrew and remove any covers from the machine, as it can cause an electric shock or injury.

Do not - place receptacles containing liquids on any surface.

Do not - adjust any part of the machine whilst rollers are running

Do not - operate the machine with loose or trailing clothing or loose hair.

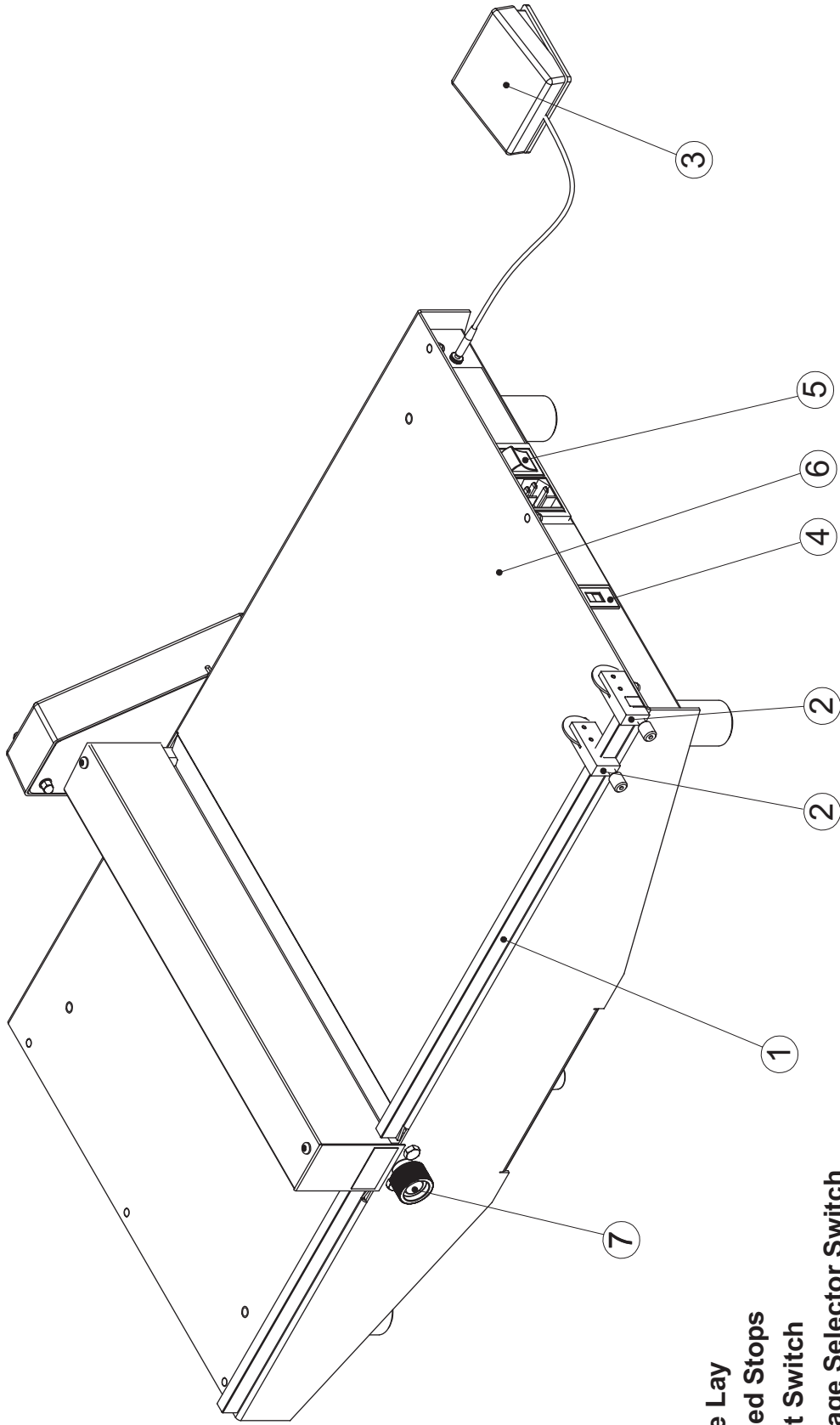

- 1. Side Lay
- 2. Speed Stops
- 3. Foot Switch
- 4. Voltage Selector Switch
- 5. Mains Switch & Fuse
- 6. Copy Table
- 7. Width Adjustment Knobs

BLANK
PAGE

REFER TO LABELED DRAWING ON PAGE 3.

1. Check that the voltage selector switch (4) is set to the required input voltage, 120V or 240V.

IMPORTANT.

For 120V operation the fuse in the mains switch (5) must be a 4A anti-surge fuse, for 240V operation the fuse must be a 2A anti-surge fuse.

2. Switch on the power, mains switch (5).

3. Set the crease length as follows:-

- (i) Line the face of the Speed Stop (2) up with the scale on the copy table (6) as shown below. (i.e. for a crease length of 100mm, line the face of the Speed Stop up with the 100mm mark on the copy table).

Line this face of the Speed Stop
up with the scale

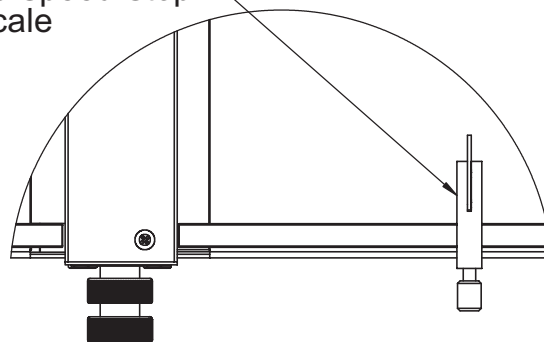

4. Slide the sheet under the speed stops and against the side lays in the direction of the creasing head. As the end speed stop drops down behind the sheet edge, slide the sheet back to contact the stop. Press the foot switch to crease the sheet. Repeat this operation for as many stops that are in use. Slide the sheet out of the machine.

5. The machine is set on the narrow crease at the factory. To change to the wider crease proceed as follows:-

- (i) Undo the inner adjustment knob (7).

- (ii) Turn the outer adjustment knob (7) until the spring loaded ball locates the wider crease position.

- (iii) Lightly tighten the inner adjustment knob, place a sheet under the head and operate the machine. This will centre the tools.

- (iv) Tighten the inner adjustment knob securely.

ITEM NO.	PART No.	QTY.	Description
1	47-300-02	1	CREASER MECHANISM - Electrocreaser 52
2	47-301-01	2	Speed Stop Assy.
3	47-069-04	1	LAY STRIP - Short - ElectroCreaser.
4	47-069-06	1	LAY STRIP - Long - ElectroCreaser 52
5	47-219-01	1	END COVER PLATE.
6	47-220-02	1	FOLDED COVER PLATE.
7	47-221-01	1	SIDE COVER - Plastic.
8	47-222-02	1	MOTOR CAM - ElectroCreaser
9	47-224-01	1	Control Board Assy.
10	47-237-01	1	Label - Crease Width
11	47-238-01	1	Label - Single Sheet Operation
12	47-253-02	1	Base Cover - Electrocreaser 52
13	47-254-02	1	Base - Hinged
14	47-255-01	4	LEG -ElectroCreaser.
15	47-257-02	1	Base - Electrocreaser 52
16	47-258-01	1	Fuse Rating Label
17	47-265-02	1	Crank Block - Cam - Ø10
18	47-265-03	1	Crank Block - Motor
19	47-266-01	1	Toroidal Transformer Assembly
20	47-267-01	1	Jack Socket Lead Assembly
21	601-109	6	FOOT - M4 - Black
22	601-150	3	NYLON PILLAR - M4 Male/Male
23	604-085	1	Gas Strut
24	606-040	1	KNURLED KNOB - Female.
25	606-041	1	KNURLED KNOB - Male.
26	610-029	1	Doga - Motor & Gearbox
27	651-094	1	FUSED POWER INLET.
28	652-034	1	Microswitch
29	652-035	1	Foot Switch
30	652-036	1	Switch - Voltage Selector - 120/240V
31	656-003	4	PCB Mounting Pillar
32	660-001	1	Warning Label - Isolate
33	672-009	1	Bridge Rectifier
34	681-013	1	Fuse - 2A - 20 x 5mm - Anti-surge
35	681-015	1	Fuse - 4A - 20 x 5mm - Anti-surge
37	401-02-025-012	2	Screw - Pan Pozi Taptite - M2.5 x 12 Lg.
38	401-02-040-006	8	Screw - Pan Pozi Taptite - M4 x 6 Lg.
39	401-02-040-008	4	Screw - Pan Pozi Taptite - M4 x 8 Lg.
41	401-02-040-010	2	Screw - Pan Pozi Taptite - M4 x 10 Lg.
42	403-01-040-006	1	Screw - Socket Cap Head - M4 x 6 Lg.
43	403-01-040-008	5	Screw - Socket Cap Head - M4 x 8 Lg.
44	403-01-040-010	1	Screw - Socket Cap Head - M4 x 10 Lg.
45	401-02-040-020	1	Screw - Pan Pozi Taptite - M4 x 20 Lg.
46	409-01-060-030	3	Screw - Socket Set - Flat Point - M6 x 30 Lg.
47	415-01-060-012	4	Screw - Hexagon Head - M6 x 12 Lg.
48	461-01-025	1	Nut - Full - M2.5
49	461-01-040	3	Nut - Full - M4
50	461-01-060	6	Nut - Full - M6
51	463-01-040	10	Domed Nut - M4
52	481-025	1	Washer - Plain - M2.5
53	481-040	16	Washer - Plain - M4
54	481-060	3	Washer - Plain - M6
55	604-080	2	Compression Spring
56			
57			
58			

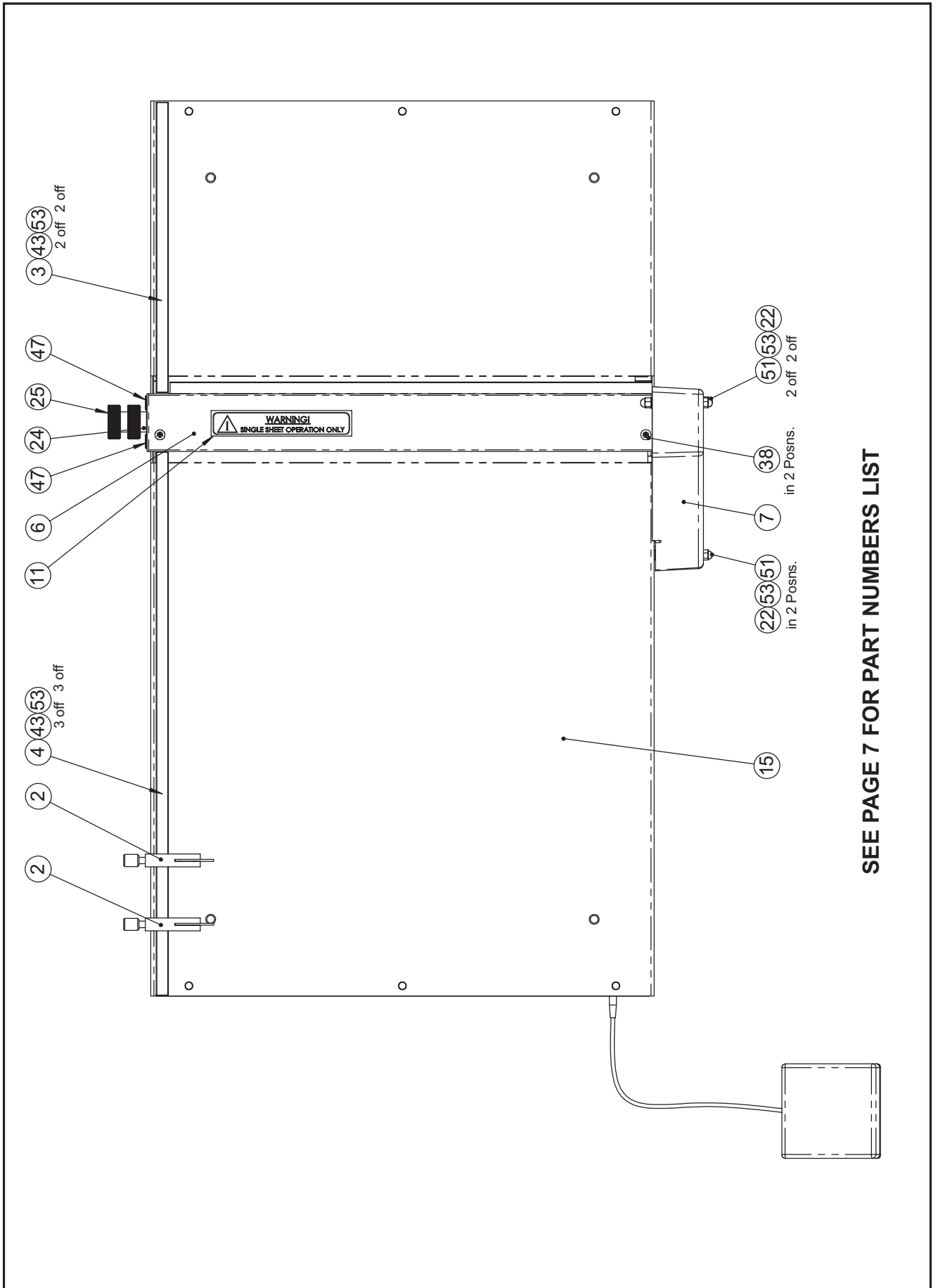

SEE PAGE 7 FOR PART NUMBERS LIST

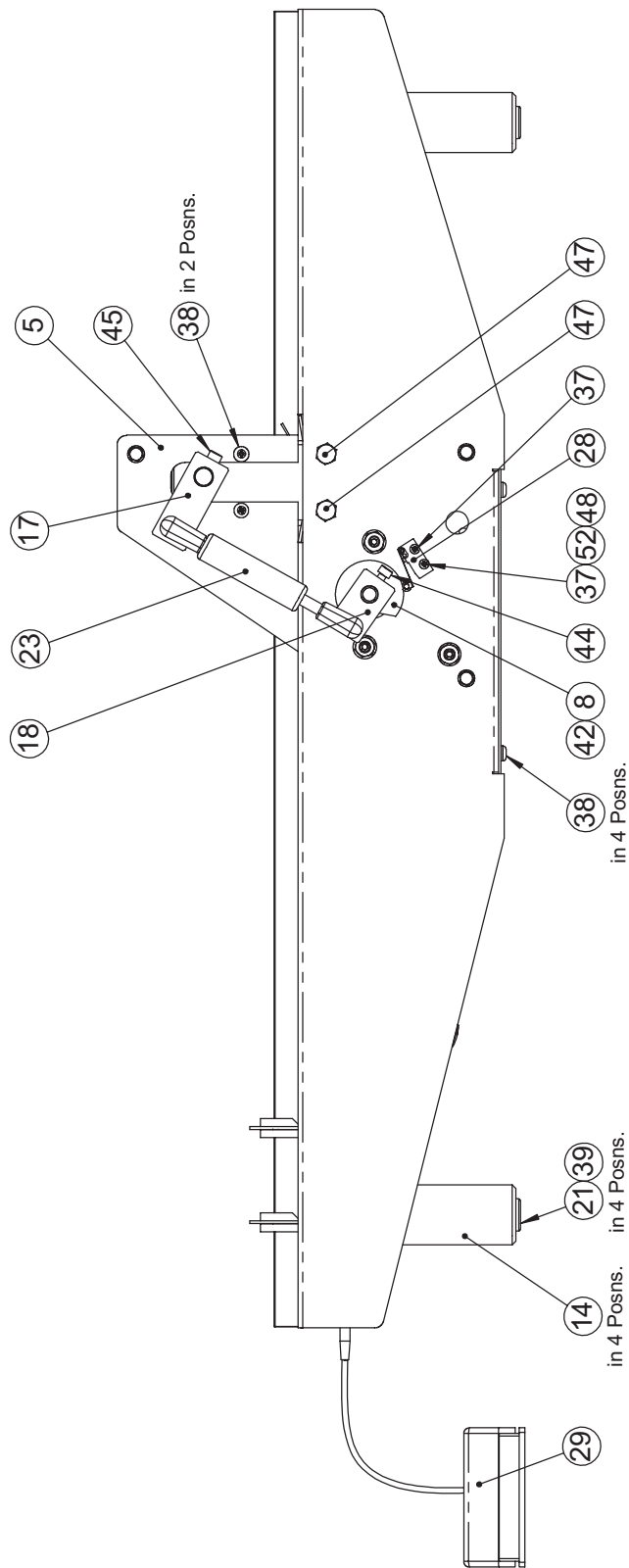

SEE PAGE 7 FOR PART NUMBERS LIST

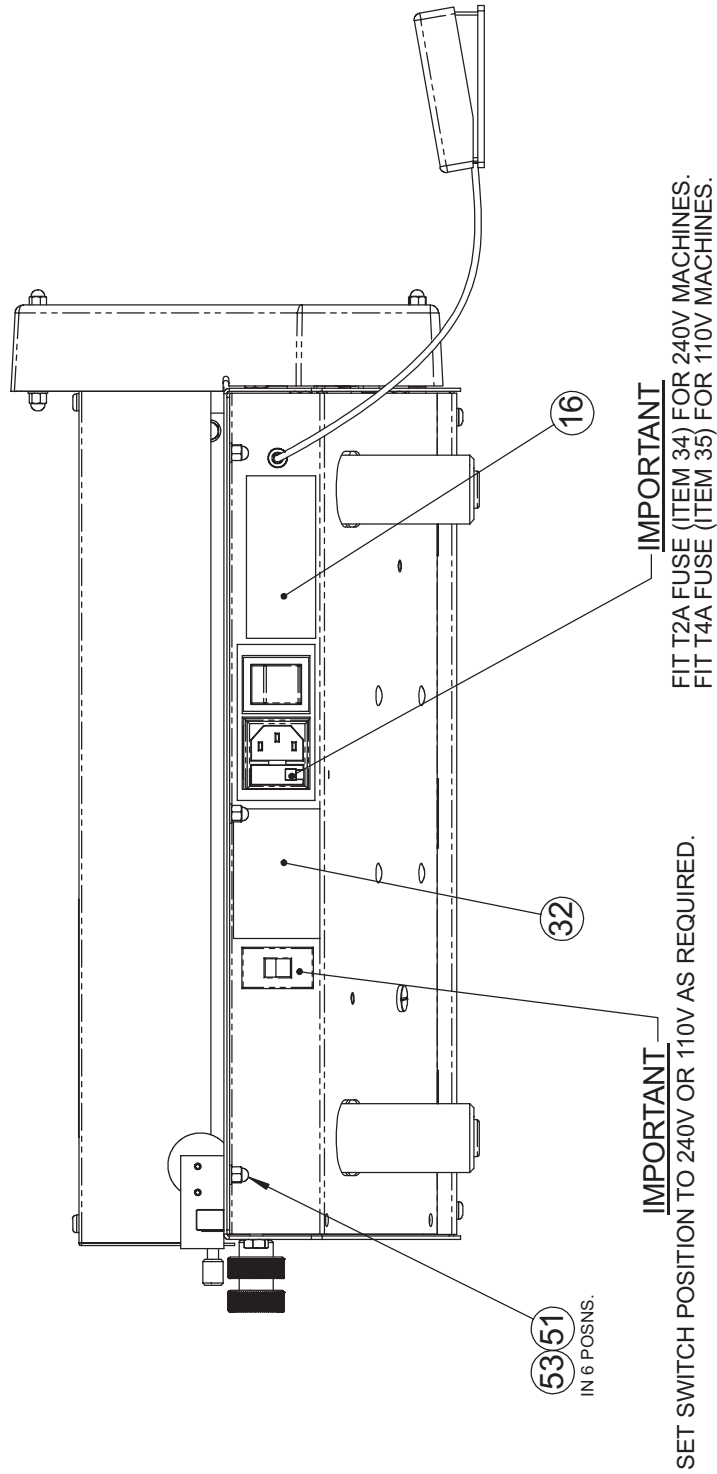

SEE PAGE 7 FOR PART NUMBERS LIST

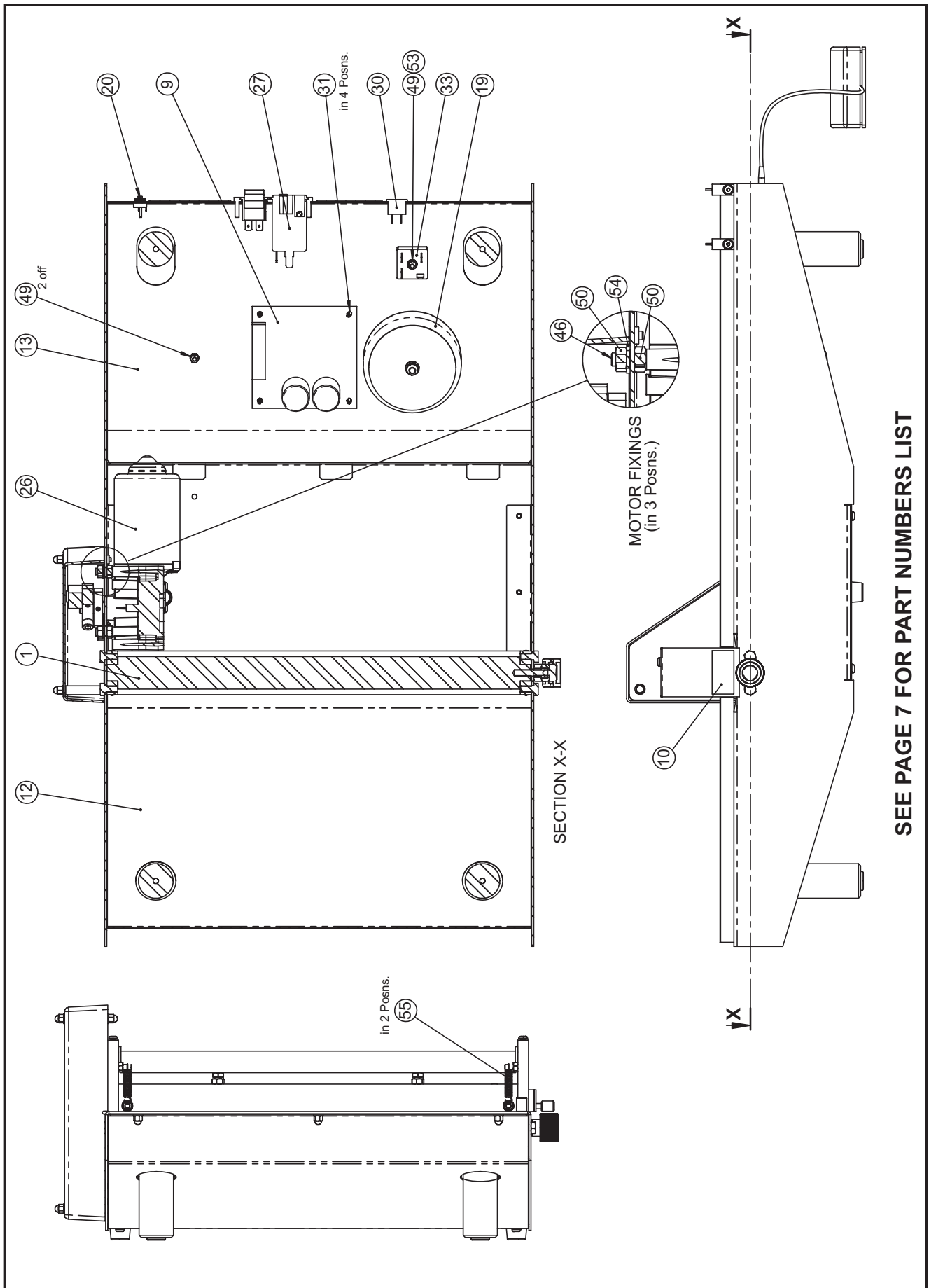

SEE PAGE 7 FOR PART NUMBERS LIST

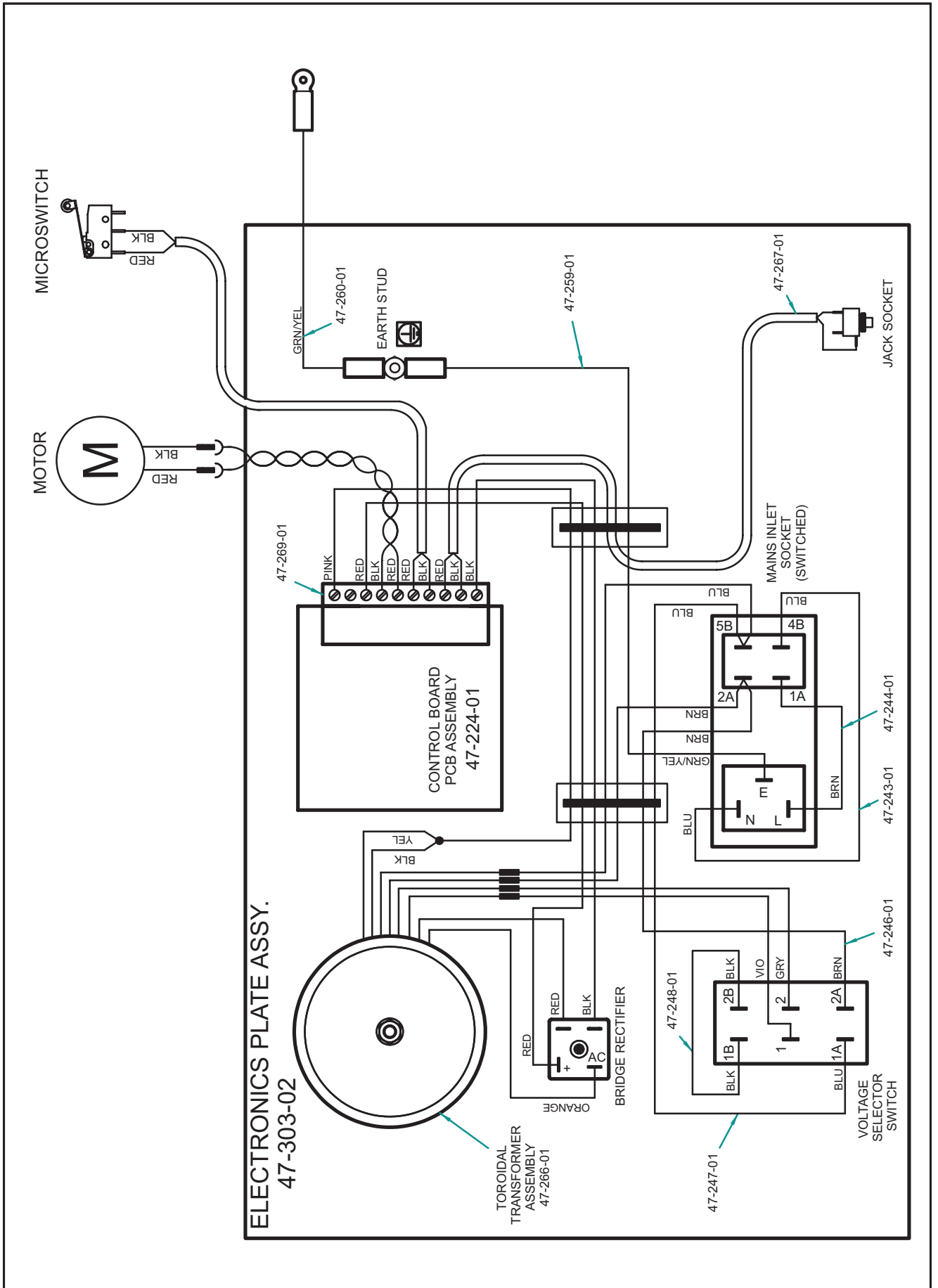

It is recommended that the following lubrication is carried out at monthly intervals

1. Remove the creasing head top cover.
2. Trickle oil into the slots, at both ends of the shaft, as shown in FIG.1 & FIG.2.
3. Liberally coat the top of the nuts and the areas of the shaft that contact the head of the nuts with PTFE grease, as shown in FIG.3.

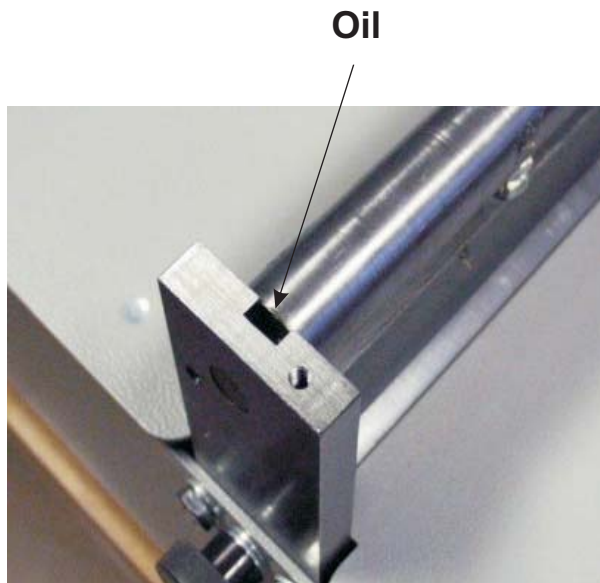

FIG.1

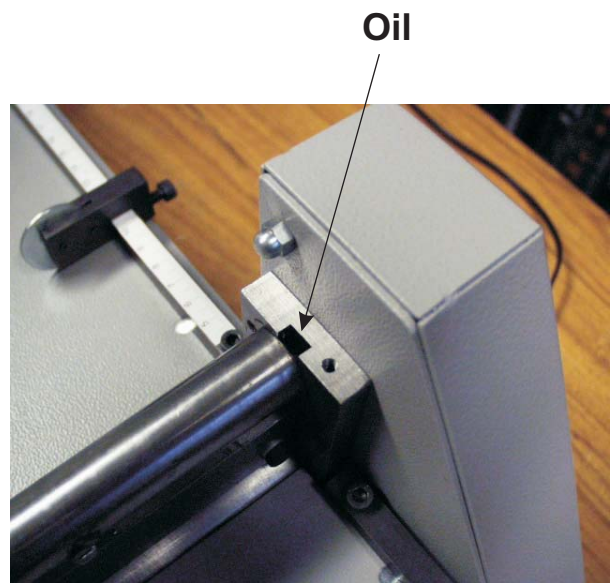

FIG.2

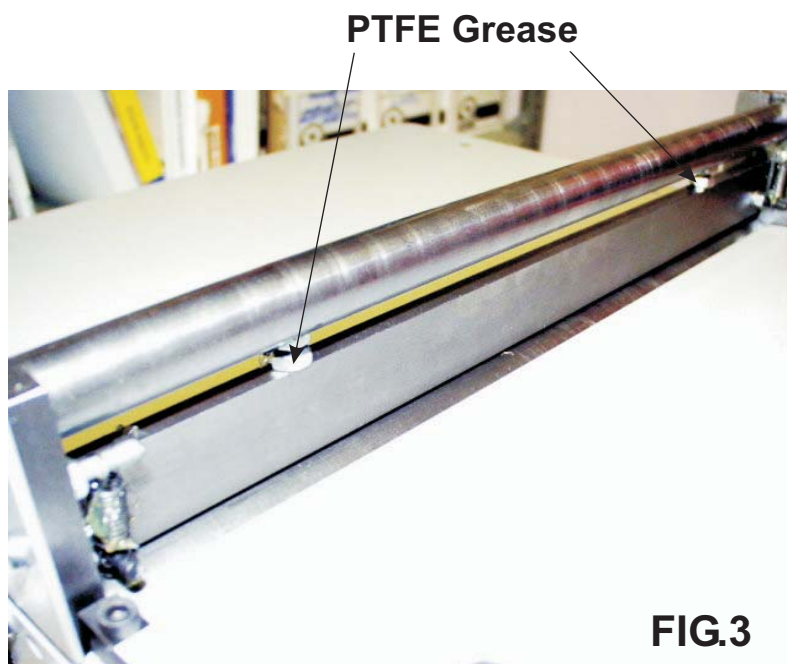

FIG.3

RECOMMENDED SPARES LIST

ITEM NO.	PART No.	QTY.	Description
1	47-300-02	1	CREASER MECHANISM - Electrocreaser 52.
2	47-301-01	2	Speed Stop Assy.
9	47-224-01	1	Control Board PCB Assembly
19	47-266-01	1	Toroidal Transformer Assembly
20	47-267-01	1	Jack Socket Lead Assembly
21	601-109	6	FOOT - M4 - Black
23	606-085	1	GAS STRUT
24	606-040	1	KNURLED KNOB - Female.
25	606-041	1	KNURLED KNOB - Male.
26	610-029	1	Doga Motor & Gearbox
27	651-094	1	FUSED POWER INLET.
28	652-034	1	Microswitch
29	652-035	1	Foot Switch
33	672-009	1	Bridge Rectifier
34	681-013	1	Fuse - 2A - 20 x 5mm - Anti-surge Ceramic (For 240V Operation)
35	681-015	1	Fuse - 4A - 20 x 5mm - Anti-surge Ceramic (For 110V Operation)
55	604-080	2	Compression Spring

NOTE....

The items listed above represents parts which are subject to wear, loss, or accidental damage, and is included for your guidance only.
Item numbers refer to the illustrations and tables in this manual.
Replacement of parts fitted to your machine require specialist knowledge and should therefore be entrusted to your dealer.