

*Morgana*

**AutoCreaser 50**

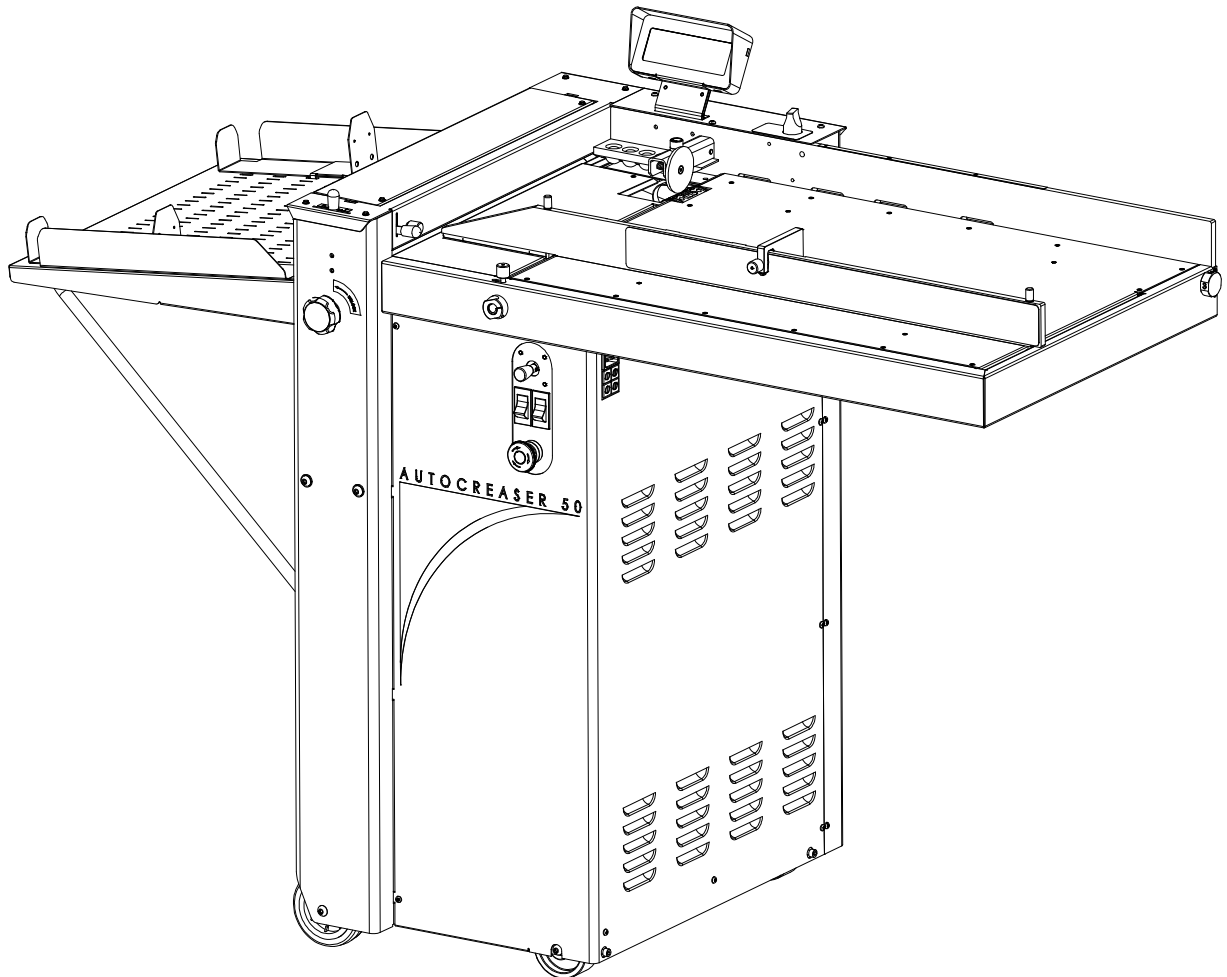

**DOCUMENT  
CREASING MACHINE  
OPERATORS MANUAL**

**Morgana Systems Limited** United Kingdom  
Telephone: ( 01908 ) 608888 Facsimile: ( 01908 ) 692399  
Website: [www.morgana.co.uk](http://www.morgana.co.uk)

**ISSUE 7**

**January**

**2008**

**SERIAL No. 710386LBAD ONWARDS**

**70-069**

<b>INTRODUCTION</b>	
The Morgana Autocreater 50	<b>PAGE 3</b>
<b>SAFETY Do's &amp; Don'ts</b>	<b>4</b>
<b>THE AUTOCREASER 50</b>	
Labelled Photograph	<b>6</b>
<b>THE CONTROLS</b>	
The control panel	<b>7</b>
Features on the control panel	<b>8</b>
<b>QUICK START GUIDE</b>	<b>9</b>
<b>OPERATING THE AUTOCREASER 50</b>	
Setting the machine	<b>12</b>
Programming the machine	<b>16</b>
Reading stored programmes	<b>17</b>
Paper jamming	<b>17</b>
<b>THE STACKER ASSEMBLY</b>	
Setting the Stacker unit	<b>18</b>
<b>PERFORATING</b>	
Equipment, spares	<b>20</b>
Setting the machine	<b>21</b>
<b>THE BLADE ASSEMBLY</b>	
Setting the blade pressure	<b>23</b>
Setting the blade alignment	<b>24</b>
<b>REPLACING CREASING BLADE SETS</b>	
Installing new blade sets	<b>25</b>
Spares	<b>26</b>
<b>TROUBLE SHOOTING</b>	<b>27</b>
<b>DISPATCH KIT</b>	<b>30</b>
<b>ACCESSORIES &amp; OPTIONS</b>	<b>31</b>
<b>RECOMMENDED SPARES</b>	<b>32</b>



**AutoCreaser 50**

The Morgana Autocreater 50 is a fully automatic suction feeding creasing system designed for use with both conventional litho and digital printers.

The feed on the Autocreater 50 can also be manually operated for use with heavy stock, very small or very large sheets, embossed or even irregular sheets.

The Autocreater 50 is capable of creasing sheet sizes to a maximum of 700mm x 500mm (27.5" x 19.7") and weights in excess of 350gsm.

The minimum sheet size when the machine is used in automatic mode is 140mm x 210mm (5½ "x 8½").

Up to sixteen creases can be programmed to a single sheet.

The crease is programmed from the leading edge of the sheet using the controls on the front panel.

A minimum distance between creases is 0.1mm

The Autocreater 50 has up to nine available memory addresses for programmed creasing operations.

The blade and anvil are mechanically controlled over their entire length and can be adjusted to accommodate various weights of media.

## **IMPORTANT**

The operating environment should be controlled to a temperature between 16° C and 27° C Maximum

### **Safety Do's & Don'ts**

- Do - read this operator manual fully before operating the machine.**
- Do - operate with the designated AC current only. Use an exclusive outlet, as overloading may cause fire or an electric shock.**
- Do - install the power cord out of the way to avoid a tripping hazard.**
- Do - beware of finger traps when replacing roller cassette and fold plates.**
  
- Do not - install the machine in an unstable place such that it tilts or shakes.**
- Do not - unplug the plug or unplug the power cord from the outlet with a wet hand, this can cause an electric shock.**
- Do not - unscrew and remove any covers from the machine, as it can cause an electric shock or injury.**
- Do not - place receptacles containing liquids on any surface.**
- Do not - adjust any part of the machine whilst rollers are running**
- Do not - operate the machine with loose or trailing clothing or loose hair.**
- Do not - under any circumstances adjust the paper gate when the machine is switched on.**

BLANK  
PAGE



**AutoCreaser 50**

**DOCUMENT CREASING MACHINE**

**Key to photograph below**

- |   |                       |    |                     |    |                        |
|---|-----------------------|----|---------------------|----|------------------------|
| 1 | Roller tilt handle    | 7  | Adjustable side lay | 13 | Control Panel          |
| 2 | Stacker assembly      | 8  | Back Stop           | 14 | Fuses                  |
| 3 | Suction slot knob     | 9  | Fixed side lay      | 15 | Gap Set Knob and Lever |
| 4 | The display unit      | 10 | Roller tilt knob    | 16 | Vacuum Bleed Knob      |
| 5 | Air separation knob   | 11 | Paper Gate          |    |                        |
| 6 | Air distribution knob | 12 | Exit Guard          |    |                        |

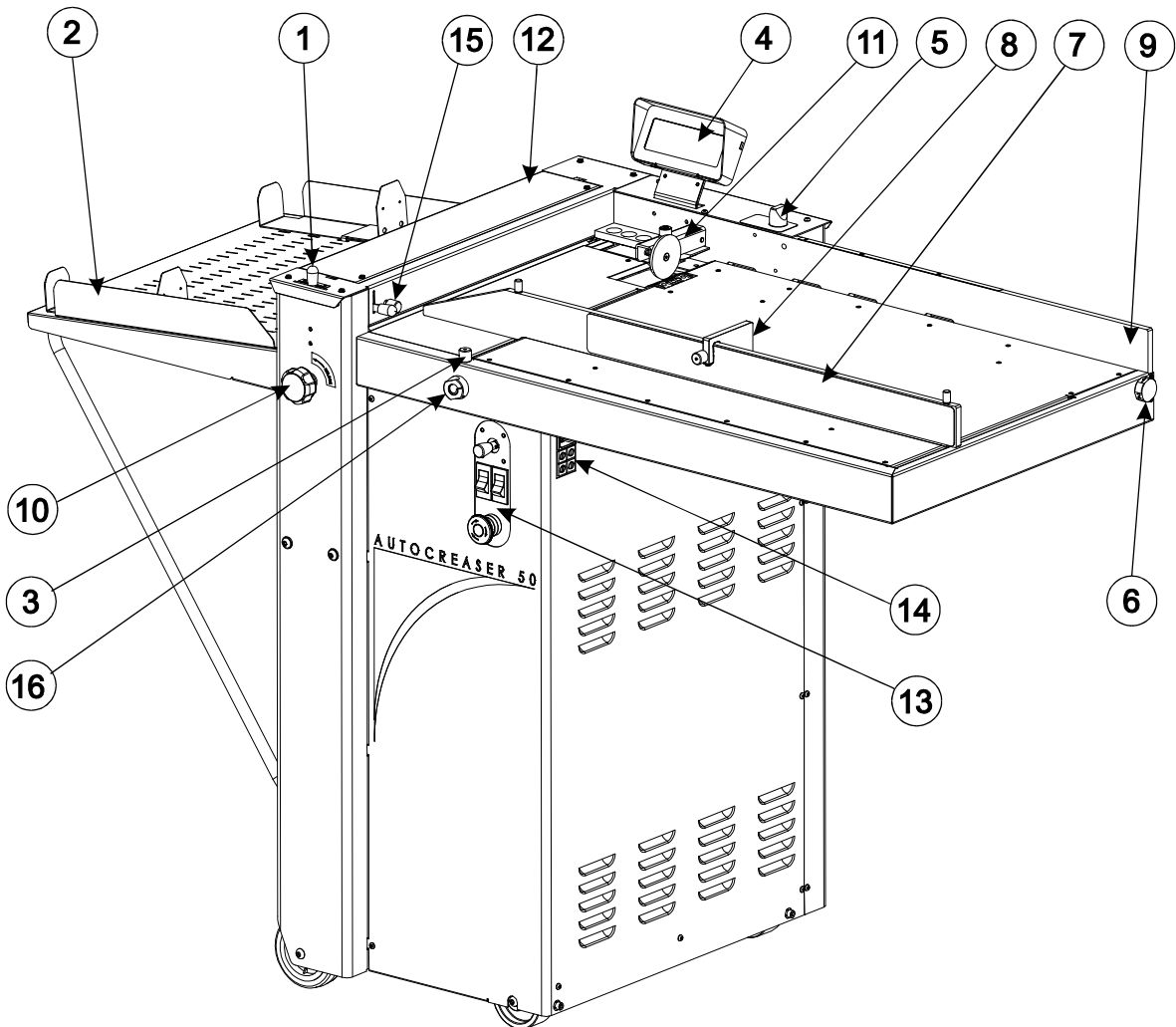

The Display Unit and the Switches on the Control Panel allow the operator to read, edit, create and initiate numerous creasing programs within the memory.

The Control Panel houses the Selection Switch, Compressor switch, System switch, and an industry standard Emergency Stop switch which will stop all power going to the machine when activated.

## THE CONTROL PANEL

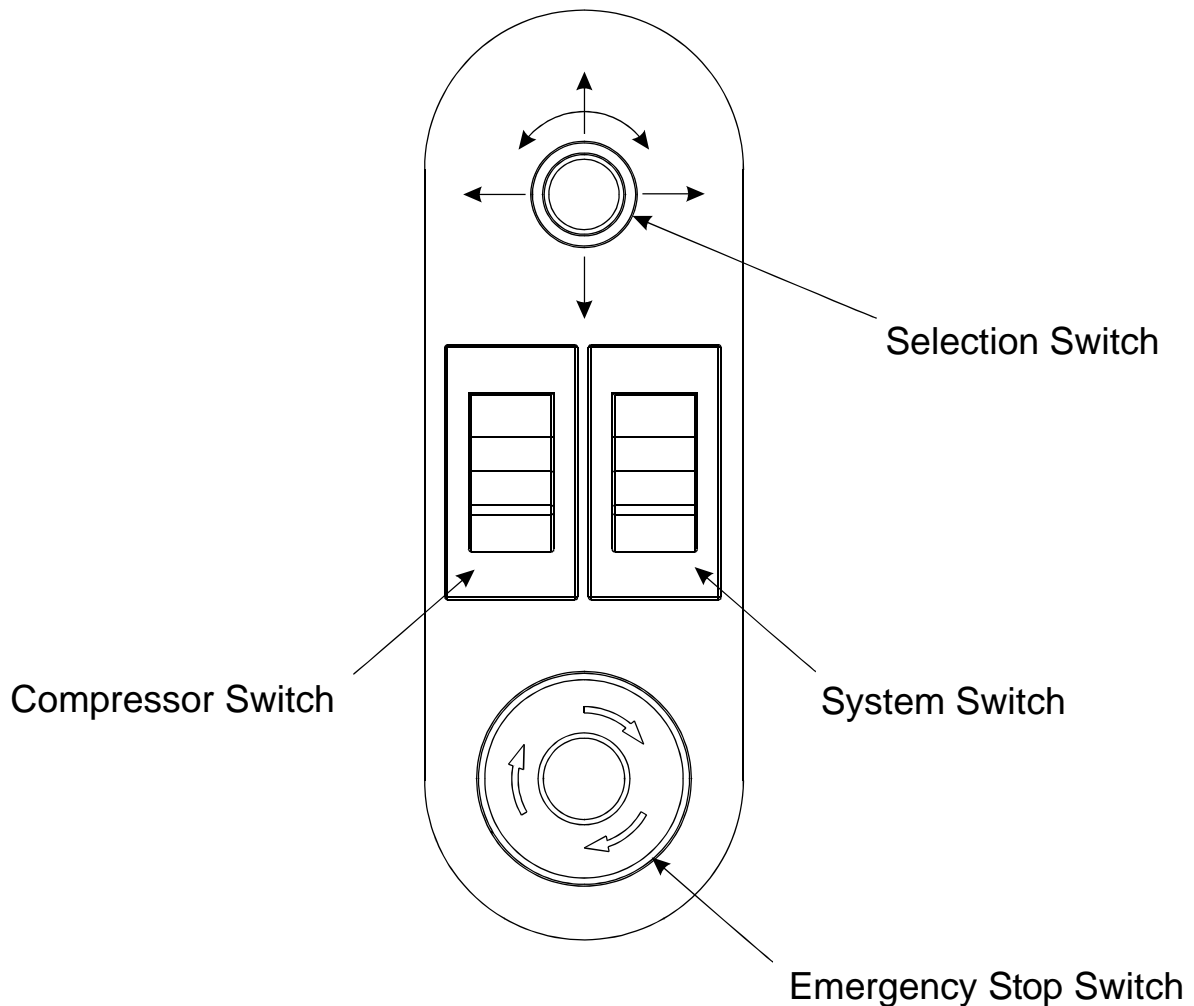

## Features on the Control Panel

### **Selection Switch**

Allows the operator to scroll through stored addresses and programs, increase or decrease the batch quantity and set a crease position.

### **System switch**

When activated the system switch will operate the motors in order to begin the creasing sequence.

### **Compressor switch**

Allows the operator to switch off the compressor unit in order to utilise the machine to manually feed sheets.

### Setting the machine to operate in automatic mode

1. Set the gap between the paper gate and the vacuum roller to approximately twice the thickness of the stock to be creased.
2. Place the stock to be creased onto the loading table against the fixed side lay.
3. Release the clamps on the adjustable side lay and slide up to the paper stack allowing a gap of approximately 0.5mm (1/64 inch) between the paper and the side lay.
4. Position the backstop and slide it up to the paper stack, also allowing a gap (as stated in the above step).
5. Turn the Emergency Stop button clockwise to switch the power on. The display unit is now illuminated, a typical start up display menu is shown below.

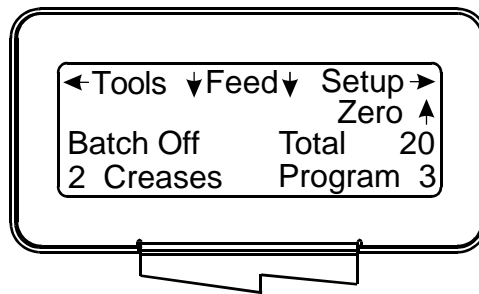

**NOTE:-**

The arrows on the display denote the direction in which the selection switch must be moved in order to access the various sub-menus.

6. Following the arrows on the display unit; move the selection switch to the right to select **Setup** (i.e. Setting the crease positions), a typical display is shown below.

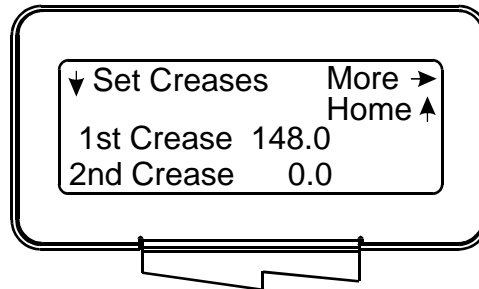

7. Following the arrows on the display unit; move the selection switch down to set the creases. The 1st Crease is now selected.

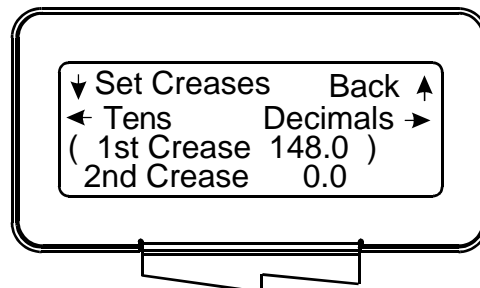

8. Move the Selection Switch to the left to select **Tens** or to the right to select **Decimals**. The **Tens** or **Decimals** (whichever has been selected) can then be adjusted by rotating the Selection Switch, (clockwise to increase or anti-clockwise to decrease).
9. To set the 2nd Crease position move the selection switch down; the 2nd Crease is selected and can be set as described in step 8. above.

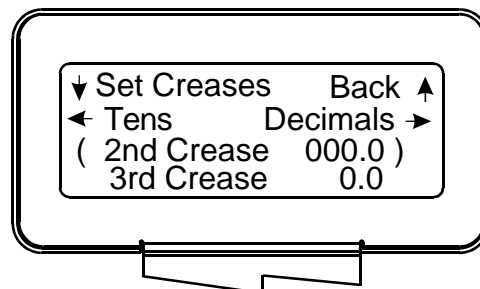

10. Further creases can be set in this way, up to a maximum of sixteen creases.

11. When the required creases have been set, move the selection switch up step by step until the display contains the word **Feed**, see below.

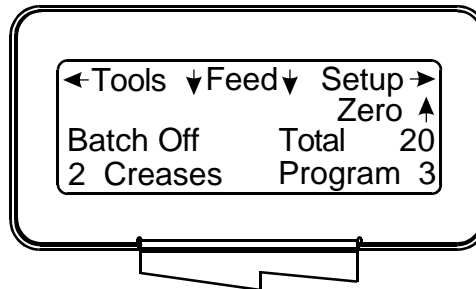

12. Press the Compressor Switch down.
13. Press the System Switch down, the display will momentarily read **Please Wait Initiating** and then return to show **Feed**.
14. Move the selection switch down to begin feeding the sheets.

**In order to manually feed sheets see instructions on page 17.**

## Setting the Machine

### Adjusting the Paper Gate

The standard setting for horizontal adjustment of the paper gate is 6.5mm (1/4") away from the mounting block. Turn disc J to make this adjustment. This setting is only intended as a guide, for instance, sheets with an upward curl will require this setting to be increased. Set the height of the Paper Gate to approximately two thicknesses of paper, by turning knob K. An excessive gap is a most likely cause of double sheet feeding.

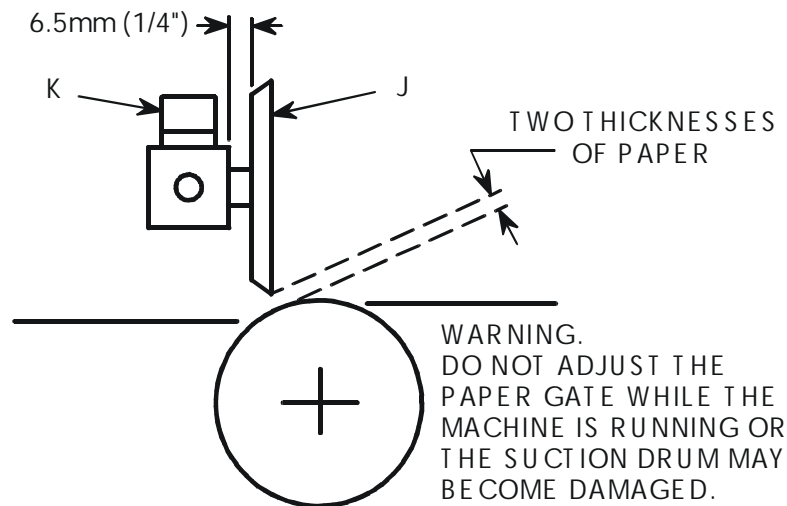

### Setting the suction slot

The suction slot is located inside the vacuum roller and can be adjusted by releasing and moving the suction knob horizontally in either direction to the required position.

For light stocks set the knob to the left and for heavier stocks set the knob to the right.

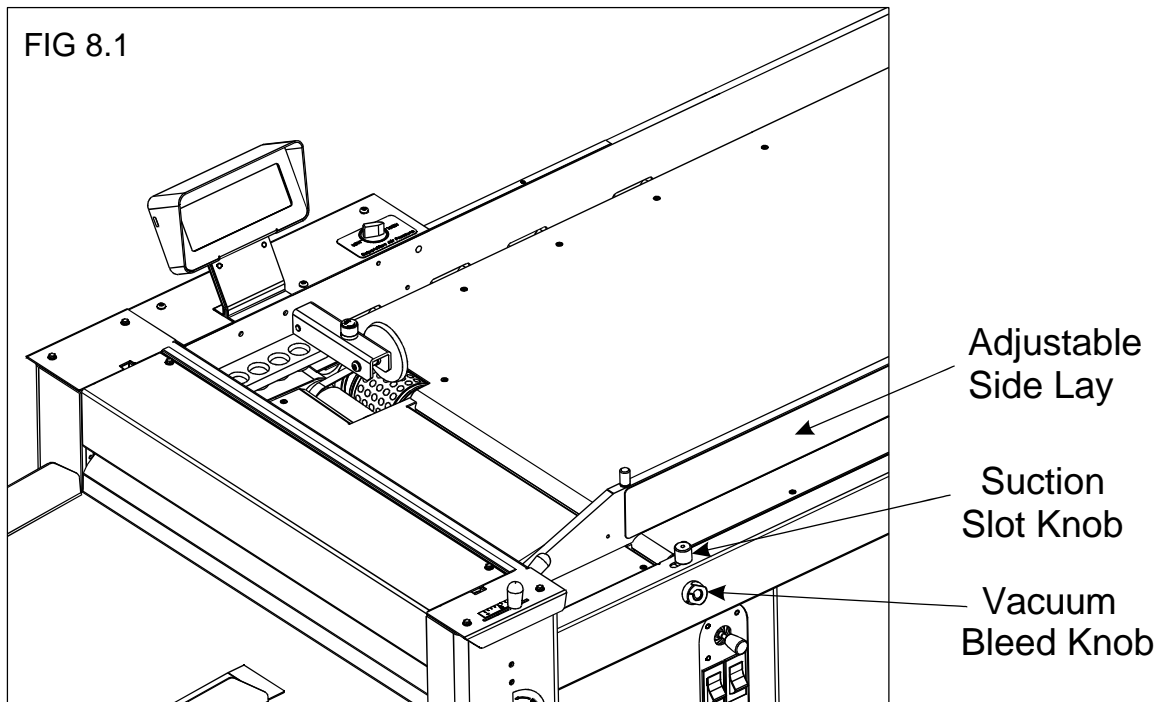

## Setting the Vacuum Bleed

Situated on the front of the feed table, the Vacuum Bleed Knob is used to allow more control of the suction on the vacuum drum.

When light weight paper of 90gsm and lower is being fed through the machine turn the knob clockwise to reduce the possibility of marking, or damage to the leading edge of the paper

## Setting the Adjustable Side Lay

Place the paper stack on to the loading table and slide up to the fixed side lay and paper gate. Release the clamps located at each end of the side lay and slide up towards the paper stack as demonstrated in fig 8.1. Allow a gap of approximately 0.5mm (1/64 inch) between the paper and the side lay.

## Setting the BackStop

Position the backstop and slide up towards the paper stack allowing a gap (as specified in the above step).

## Setting the Air Distribution

Depending on the length of the sheet to be creased, the air distribution knob can be rotated to various positions in order to supply air to different ports. Position 1 is recommended for most sheet sizes. However, a better result may be obtained by using the below settings or by experimentation.

- Position**
- 1 – For A5 sheets or 8 inches long, port 1 open.
  - 2 – For A4 sheets or 11 inches long, front port and port 2 open.
  - 3 – For A3 sheets or 17 inches long, front port and port 3 open.
  - 0 – For longer sheets in order to supply air to the centre of the stack, port 2 open

## Setting the Air Separation Pressure

To control the amount of air supplied to the ports, the air separation knob can be adjusted by first rotating the knob to unlock its position, then push the knob down to the required position and rotate the knob to re-lock its position.

## Setting the Roller Tilt Mechanism

The roller tilt mechanism has been designed to compensate for when the creasing position on the sheet is not square. This could be due to an inaccuracy in the media or if the roller tilt mechanism has been incorrectly set. The mechanism will be set to zero (square) when the machine is supplied.

To set the mechanism, unlock the roller tilt knob located below the roller tilting handle by turning anti-clockwise. Move the roller tilt handle left or right in order to compensate for any inaccuracy. When the position is set, ensure to lock the roller tilt knob before operating the machine. Repeat the above procedure until the creasing position is square.

## Setting the positions of drive wheels and hubs

It is important that the drive wheels and drive hubs on the roller shafts are arranged evenly across the width of the media being creased. This is done to ensure that the media is accurately driven and supported through the rollers.

The drive wheels and hubs are fixed to the rollers by means of a grub screw. To locate this grub screw the rollers can be rotated by operating the motor manually.

**DO NOT ROTATE THE DRIVE ROLLERS BY HAND.**

To operate the motors manually, switch the machine 'on' at the Emergency Stop switch. Following the arrows on the display unit, move the selection switch to the left to select **Tools**, the display will now show the Tools sub-menu. Press the system switch down and then move the selection switch to the left or to the right, to rotate the rollers in short pulses. Lift the exit guard to see if the grub screws in the drive wheels and hubs can be seen. If the grub screws cannot be seen, lower the exit guard and rotate the rollers by moving the selection switch to the left or to the right. Loosen the drive wheels and hubs with a 2mm allen key. Arrange the drive wheels and hubs as shown in FIG 10.1. In order to avoid marking on some types of media ensure a gap between the drive wheels and hubs. This procedure should be repeated when installing perforating blades and anvils onto the drive wheels and hubs.

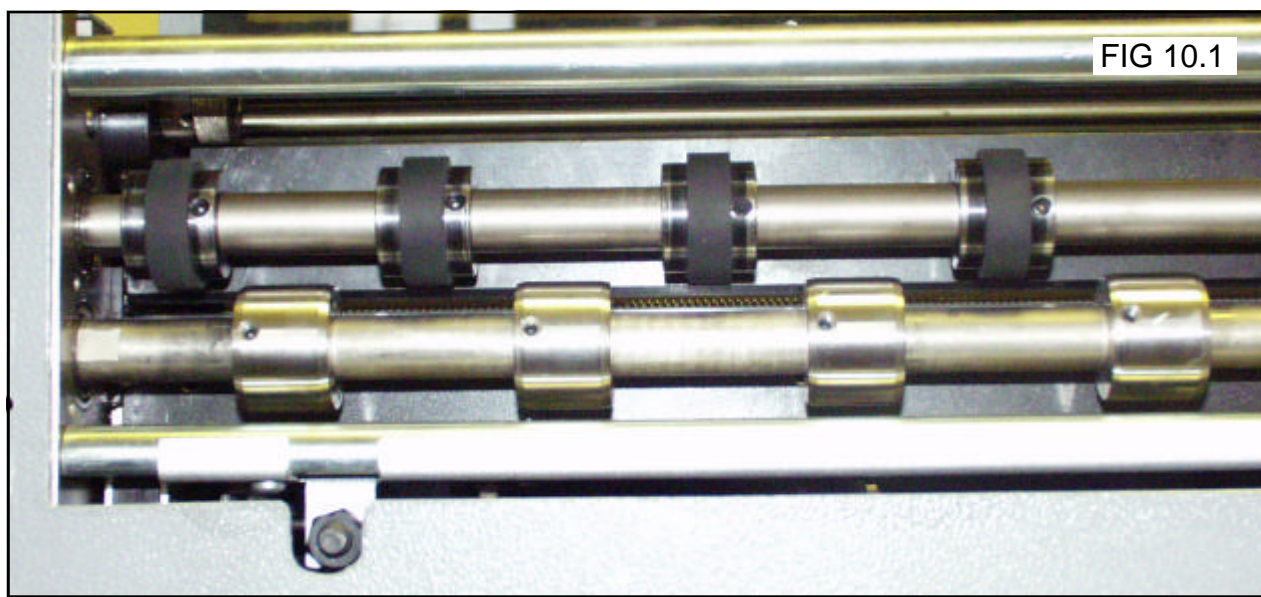

## Set Feed

The length of suction on the sheet of paper being fed can be adjusted by setting the feed type as follows:-

- (i) From the start up menu, move the selection switch to the right to select **Setup**.
- (ii) Move the selection switch to the right, one click at a time, until the display contains the words **Set Feed**.
- (iii) Move the selection switch down to select the required feed type (**Standard Pulse**, **Medium Pulse**, **Short Pulse**, or **Stream Feed**)
- (iv) Move the selection switch to the right to select **Ok**.

Use **Standard Pulse** for all standard size sheets, general purpose.

Use **Medium Pulse** for short non-standard sheets.

Use **Short Pulse** for very short sheets.

Use **Stream Feed** for high throughput, see note below.

### **NOTE.**

Do not use stream feed for creases less than 32mm from the leading edge of the paper.

## Setting the infeed roller gap set

The gap between the infeed rollers must be adjusted to suit the stock being used. The gap set can be adjusted as follows:-

1. Place a sample sheet of the stock to be used onto the feed bed.
2. From the start up menu, move the selection switch to the left to select **Tools**.
3. Press the system switch down.
4. Move the selection switch to the left, one click at a time, until the sheet is gripped in the infeed rollers. Test the grip of the sheet in the rollers by trying to remove the sheet by hand, the sheet should be lightly gripped by the rollers. If the grip on the sheet is too light or too heavy it can be adjusted as follows:-
  - (i) Turn the gap set locking knob anti-clockwise to unlock.
  - (ii) Move the gap set lever up to increase the gap or down to decrease the gap.
  - (iii) Turn the gap set locking knob clockwise to lock.

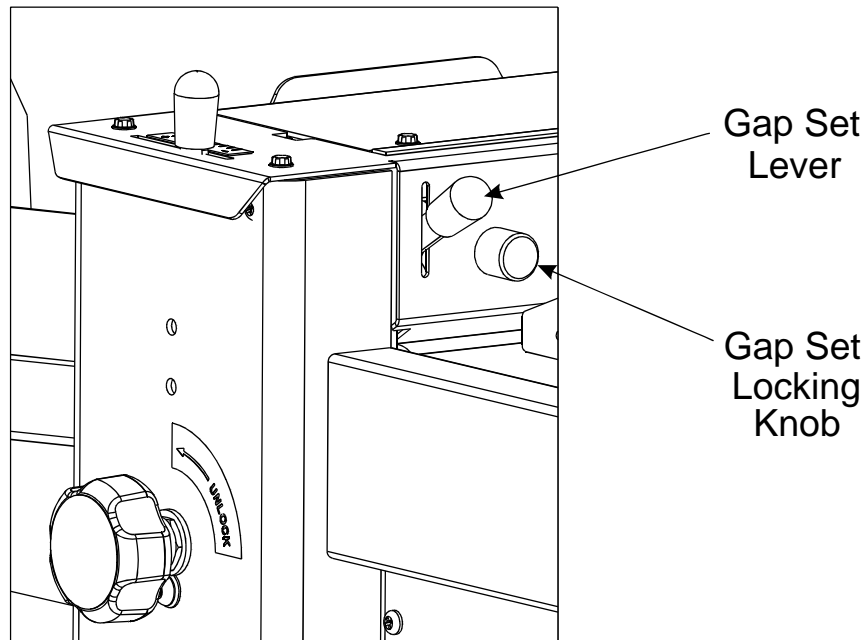

## Programming the machine

1. Switch the power 'on' by turning the Emergency stop button clockwise to release the safety latch. The display is now switched on.

### Setting the batch quantity and Dwell Time

2.
  - (i) Move the selection switch to the right to select **Setup**.
  - (ii) Move the selection switch to the right to select **More**.
  - (iii) Move the selection switch to the right again to select **More**.
  - (iv) Move the selection switch down to select **Set Batching**.
  - (v) Rotate the selection switch clockwise or anti-clockwise to adjust the batch quantity in increments of 5.
  - (vi) Move the selection switch down to select **Dwell Time Secs**.
  - (vii) Rotate the selection switch clockwise or anti-clockwise to adjust the dwell time, in seconds, this is the period of time between each successive batch quantity.

### Setting the crease positions

3. Move the selection switch up, one click at a time, until the start up menu is displayed as shown below.

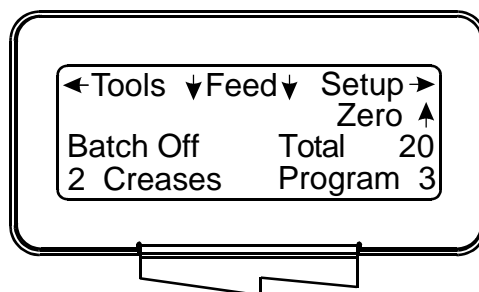

- (i) Move the selection switch to the right to select **Setup**.
- (ii) Move the selection switch down to select **Set Creases**.
- (iii) Move the selection switch to the left to select Tens, or to the right to select Decimals.
- (iv) The Tens or Decimals (whichever has been selected) can then be adjusted by rotating the Selection Switch, (clockwise to increase or anti-clockwise to decrease).
- (v) Adjust all other digits for the 1st Crease position as described in steps (iii) and (iv), (i.e. move the selection switch to the left to select the Tens or to the right to select Decimals and then rotate the Selection Switch to adjust its value.
- (vi) Move the selection switch down to select the 2nd Crease. The second crease will automatically start at 0000.0. Crease positions can be set in increments of 0.1mm.
- (vii) Set the 2nd Crease position as described in steps (iii) to (v) above.  
Further creases can be set in this way, up to a maximum of sixteen creases.

### Storing the crease positions

4. Once the crease positions are correctly entered, they can be stored as follows.
  - (i) Move the selection switch up, one click at a time, until the display contains the word **More**.
  - (ii) Move the selection switch to the right, one click at a time, until the display contains the word **Programs**.
  - (iii) Move the selection switch down to select **Save Settings**.
  - (iv) Rotate the Selection Switch to select the Program number (1 to 9).

- (v) Move the selection switch to the right to select **Select**.
- (vi) Move the selection switch to the left to select **Yes** or to the right to select **No**.

## Running the machine

5. To run the job with the selected settings.
  - (i) Press the Compressor Switch down.
  - (ii) Press the System Switch down.
  - (iii) Move the selection switch down to begin feeding the sheets.

To stop feeding the media at anytime during the program, flick the selection switch up. The machine will complete its creasing operation if a sheet has already been fed through the paper gate.

## Reading stored programs

Any of the nine stored programs can be accessed and read as follows:-

- (i) From the start up menu, move the selection switch to the right to select **Setup**.
- (ii) Move the selection switch to the right, one click at a time, until the display contains the word **Programs**.
- (iii) Move the selection switch down to select, **Retrieve Program**.
- (iv) Move the selection switch to the right to select, **Select**.
- (v) Rotate the selection switch clockwise or anti-clockwise to select, **Program 1** to **Program 9** and view the program settings.

## Paper jamming

In the event of a paper jam occurring whilst the machine is operating the display will read **Paper Jam**. In order to remove the paper causing the jam, move the selection switch to the left or to the right to drive the paper forwards or backwards in short pulses.

## Setting the machine to operate in manual mode

In order to feed heavy stock, very small or very large sheets, embossed or even irregular shaped sheets, it may be required to operate the machine manually. The machine can be programmed and set up in exactly the same way as explained when operating the machine automatically. However, when setting up the machine the paper gate must be raised to its highest position for the sheets to be fed freely. Operating the machine manually will also require the suction length to be continuous in order to accommodate various types of stock. Therefore, the feed should be set to **Standard Pulse** see page 14.

The machine can now be started by activating the System switch to 'on'. **Do not activate the Compressor switch**. Move the selection switch down to select **Feed** and begin to slide the sheets individually through the paper gate until they are driven by the drive belts. To stop feeding the sheets, move the selection switch up and then the System Switch up.

The stacker unit on the Autocreater 50 is used to catch the sheets once they have been creased or perforated.

## Setting the Stacker assembly

1. Assemble the stacker unit to the machine as shown in fig 13.1 below.

### **Important**

**Ensure that the stacker unit has been assembled to the machine properly. However, if it has not, the connection on the magnetic switch will be broken and the machine will not operate (see Trouble shooting pages for details).**

There are two side guides on the stacker unit; a left handed (fixed) guide and a right handed (movable) guide held on by a magnetic strip. There is also a left hand extension guide. The guides will control the way in which the paper is collated by setting their positions on the stacker bed.

2. Place a single sheet (from the stack to be creased / perforated) on to the stacker bed against the fixed 'left hand' guide.
3. Position the 'right hand' side guide on to the stacker bed leaving a minimum clearance of approximately 1mm each side of the sheet.

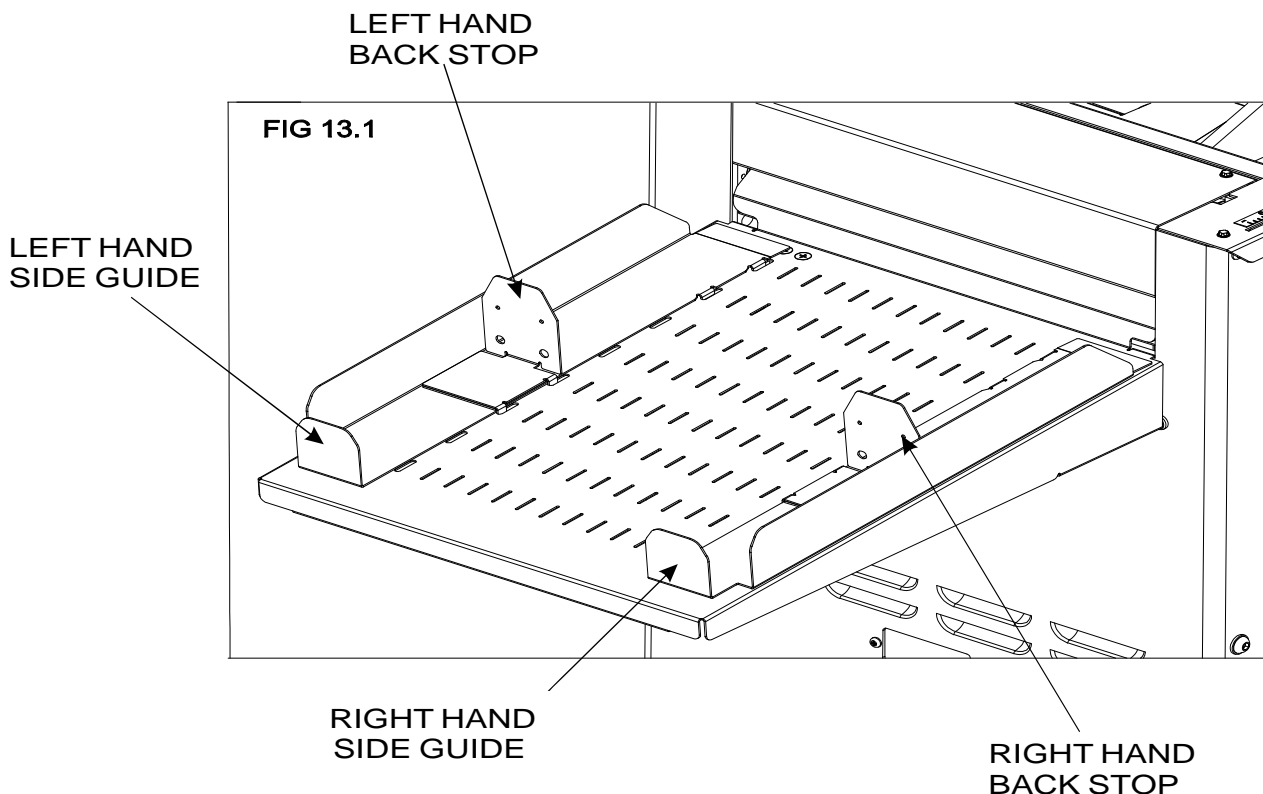

4. Whilst the sheet is between the two guides on the stacker bed, set the distance between the top of the sheet and the backstop flanges to approximately 5mm.
5. For shorter sheets, the back stop can be used (as shown in FIG 13.1 to adjust the position of the paper stack.

### TIPS



- One of the back stops supplied with the machine (on the stacker assembly) can also be used as a tool holder as demonstrated in the photograph (left).
- The scale on the bed can be used to measure the desired creasing or perforating position on the sheet.

Once the machine is set-up, the Autocreaser 50 can be used to perforate or crease.

**Note**

**Perforating and creasing can be carried out simultaneously. However, if any adjustment is made to the roller tilt mechanism in order to compensate for the perforation line being 'out of square', this may effect the accuracy of the crease. If this occurs creasing and perforating must be carried out as separate operations.**

The components and tools required to install the perforator are contained in the despatch kit supplied with the machine, they are listed below.

- 1 off Set of standard perforation '56 tooth' blades.
- 1 off Set of standard hardened anvils.
- 1 off Perforator stripper.
- 1 off Scoring wheel
- 1 off 3mm bondhus wrench / allen key
- 1 off 2mm bondhus wrench / allen key

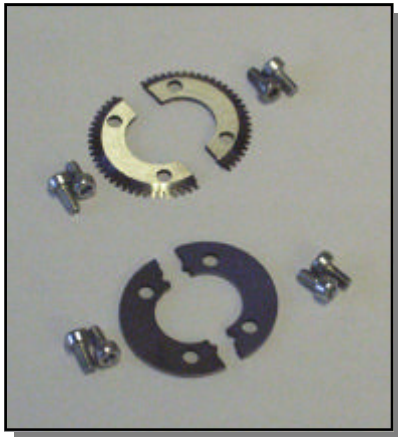

The perforator blades are split into two matching halves and are fitted to the drive wheels as shown in the photograph using the four screws supplied.

A hardened anvil is fitted to the drive hub as shown in the photograph also using the four screws supplied. Again the anvils are made from matching halves.

**Important: The perforator blades are very sharp and care must be taken whilst handling. Do not mix the matching pairs of blades or anvils.**

**Perforating 'Spares' kits**

For perforating and other types of paper, various spares kits are available which can be assembled to the machine in the same fashion. They are listed below along with a range of scoring wheels,

<b>Perforating blades</b>	56 teeth	Part Number <b>1-99-41</b>	– Standard stock / fine perforations.
	28 teeth	Part Number <b>1-99-12</b>	– Medium stock / medium perforations.
	20 teeth	Part Number <b>1-99-10</b>	– Heavy stock / coarse perforations.
<b>Anvils</b>	Standard	Part Number <b>1-99-35</b>	– For all blade types

All of the blades and anvils are supplied with fixings.

**\*Perforator stripper**      Standard Part Number **78-013**

\*It is recommended that for multiple perforations, a separate perforator stripper is used for every perforating blade set fitted in the creasing unit.

## Setting the machine

1. Turn the mains supply to the machine 'off'.
2. Remove the stacker unit and open the exit guard.
3. Locate and remove the blades / anvils from the despatch kit supplied with the machine.
4. Using the 2mm allen key (supplied), loosen the drive wheel that is to accommodate the blades.
5. Slide the drive wheel away from any obstructing drive wheels or hubs in order to mount the blades.

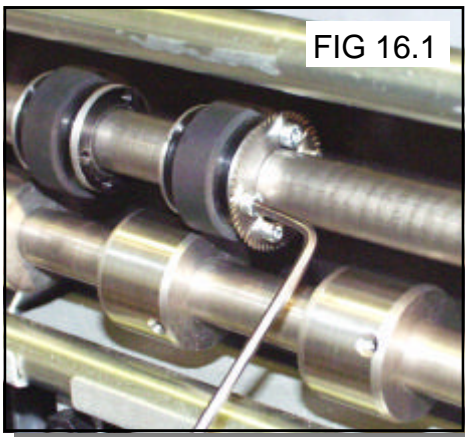

6. Using the 2.5mm allen key (supplied), take one of the matching pairs and mount on to the drive wheel. Do not secure the blade.
7. Mount the other matching pair to the drive wheel as shown (fig 16.1). Secure the blades to the wheel ensuring not to over tighten grub screw.
8. Mark on a single sheet the desired perforating position. Feed the sheet through the machine manually until the mark can be seen. Use this mark to assist in fixing the position of the perforating drive wheel to the roller drive shaft.

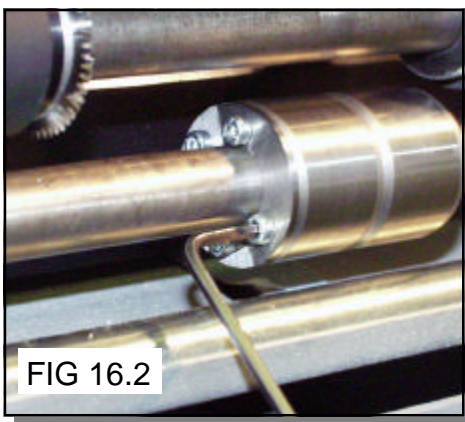

9. Using the 2mm allen key, loosen the drive hub nearest the perforating drive. Slide the drive hub away from any obstructing drive wheels or hubs in order to mount the anvils.
10. Using the 2,5mm allen key, take one of the matching pairs of anvils and mount to the drive hub. Do not secure the anvil.

11. Mount the other anvil ensuring that they have matched on the drive hub. Secure the anvil to the hub ensuring not to over tighten grub screw as shown in fig 16.2.
12. Slide the drive hub towards the perforating drive wheel until there is a clearance of 0.5mm.
13. To prevent damage to the blades or the anvils, do not force the drive wheel against the hub.
14. Fix the perforator stripper adjacent to the drive wheel and blade as shown.
15. Operate the machine and test the perforations for form.

**It is important that the drive hubs are arranged evenly across the width of the paper in order to reduce the risk of jamming.**

For multiple perforations repeat the above procedure.

Shaft support blocks are mounted on the top and bottom shafts. If they are in a position that obstructs perforating, they can be slid along just enough to clear the hubs. They should be mounted as near to the centre of the machine as possible, to maximise support. The depth of perforation can be adjusted by first loosening the socket set screws, in the support block, with a 2.5mm allen key. Insert the 2.5mm allen key into the grub screw, push the allen key up to decrease the perforating depth or down to increase the depth of perforation. Re-tighten the socket set screws.

(Note. This adjustment can also be carried out on the bottom shaft)

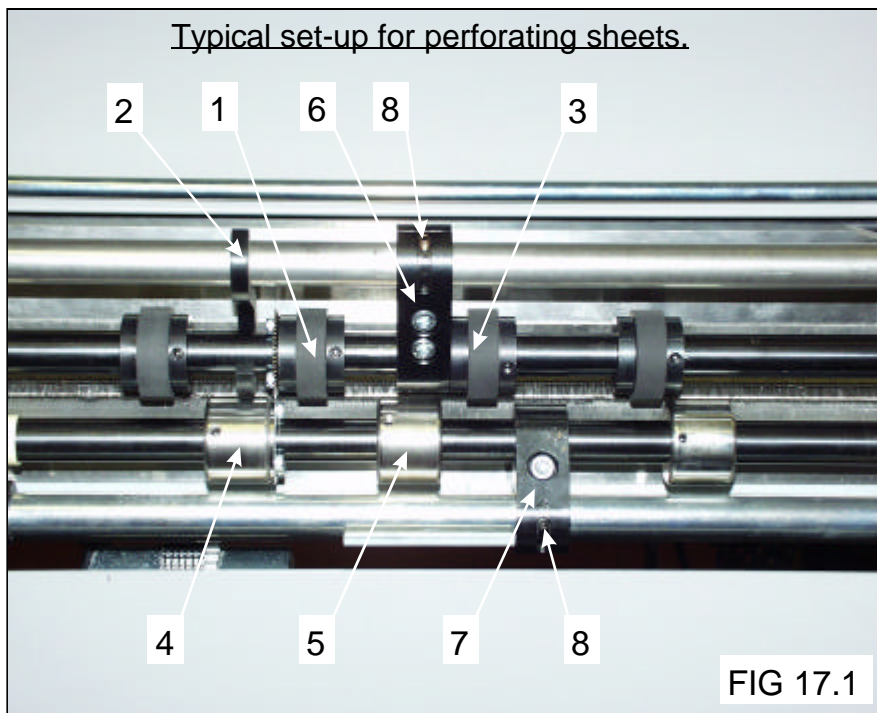

- |   |                               |
|---|-------------------------------|
| 1 – Perforating drive wheel with mounted blades | 5 – Standard drive hub        |
| 2 – Perforator stripper                         | 6 – Upper shaft support block |
| 3 – Standard drive wheel                        | 7 – Lower shaft support block |
| 4 – Drive wheel with mounted anvils             | 8 – Grub screw                |

**Always remove blades and anvils once the perforating operation has been completed to avoid marking on digital or delicate media.**

## Adjusting the blade pressure (no paper required)

- (i) Switch the power 'on' by turning the Emergency stop button clockwise to release the safety latch. The display is now switched on and will show the start up menu as shown below.

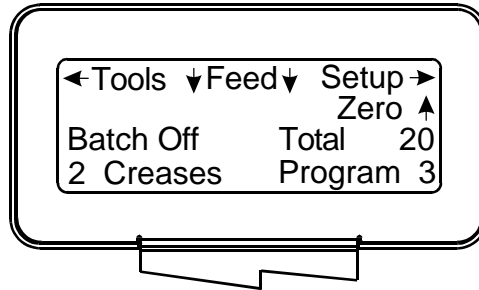

- (ii) Move the selection switch to the left to select **Tools**.
  - (iii) Move the selection switch down to select **Set Blade Pressure**.
  - (iv) Press the system switch down.
  - (v) Move the selection switch to the right, the machine will activate and the blade will move to top dead center. The display will now read **Blade is moving to TOP DEAD CENTER** and then change to read **Blade Pressure May Now Be Adjusted See Operators Manual**.
2. Raise the exit guard
  3. Using a 6mm allen key, unlock the shoulder bolts (labelled with scale transfer) positioned at each end of the creasing blade.
  4. Turn the adjustment cam to adjust the blade pressure. Increasing the gradient on the scale will increase the blade pressure.
  5. Ensure that the shoulder bolts are locked after setting.

The diagram below demonstrates the adjustment of the blade pressure

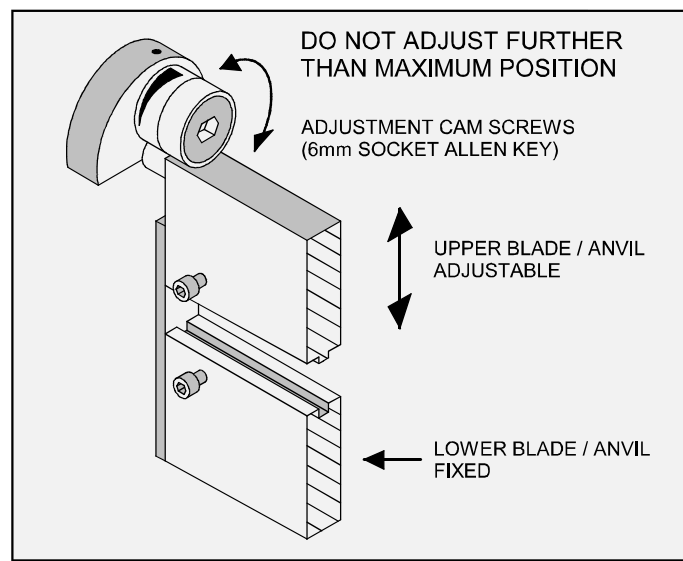

## Adjusting the blade alignment

It is extremely important that the blade and anvil assembly within the creasing unit is correctly aligned. Misalignment of the blade or anvil can lead to damaged profiles and subsequently poor quality creasing so it must, therefore, be corrected immediately. If the blade set is misaligned, the media being driven will be subject to scoring or even tearing at any point along the crease line. **Please note that to avoid damage to the blade set, adjustment should only be made in small increments.** The below sketch demonstrates how the blade alignment can be carried out.

Adjustment can be made at either of the blade or anvil. The two clearance holes positioned above the roller tilt mechanism are the front alignment (one for blade, one for anvil). The two holes are repeated on the back of the machine for the back alignment.

1. Remove the stacker unit from the Autocreaser
2. Unlock and centralise the roller tilt mechanism in order to locate the heads of the front alignment screws.
3. Using a 3mm allen key, loosen the cap head type locking screws located on the front face at both ends of the blade /anvil as shown below.
4. Using a 4mm allen key, locate the two front or back alignment screws in the side frame in order to adjust the blade / anvil.
5. The upper screw of the two, will adjust the upper blade / anvil whereas the lower screw will adjust the lower blade / anvil both in very small increments.
6. In order to obtain the required position, adjust either the blade or the anvil by a small amount and then operate the machine to test the form of the crease. Repeat the exercise until centralisation is located.
7. Using a 3mm allen key, lock the cap head type screws (as per step 3) on both the upper and lower blade / anvil.

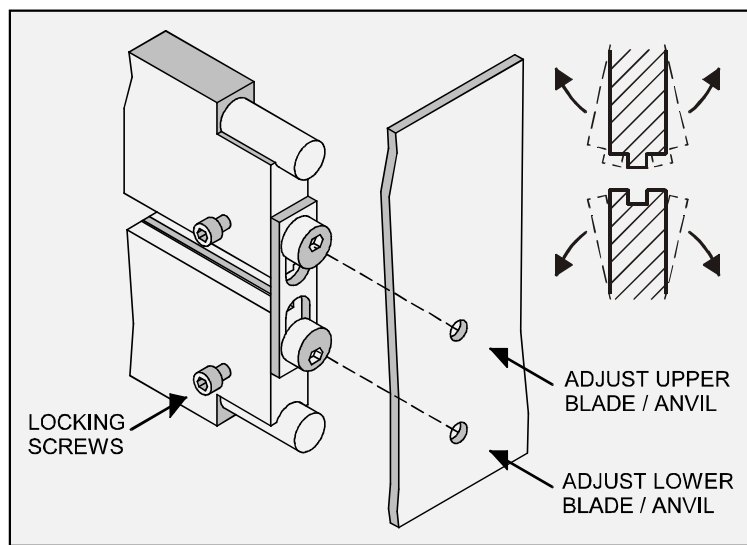

1. Before removing the blade assembly, ensure that the lower blade / anvil is NOT at 'top dead centre', Switch the machine off.
2. Remove the stacker unit and lift the exit guard.

Blade Extractor Tools

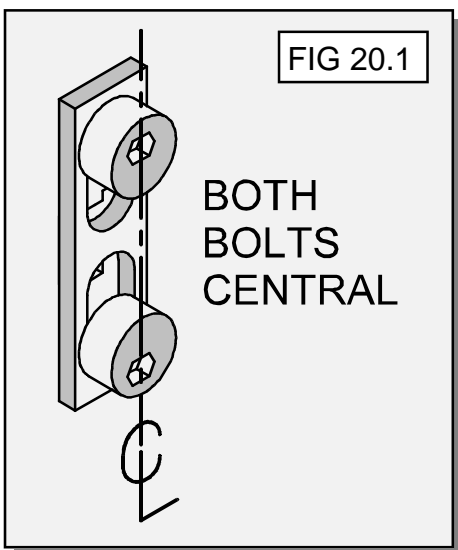
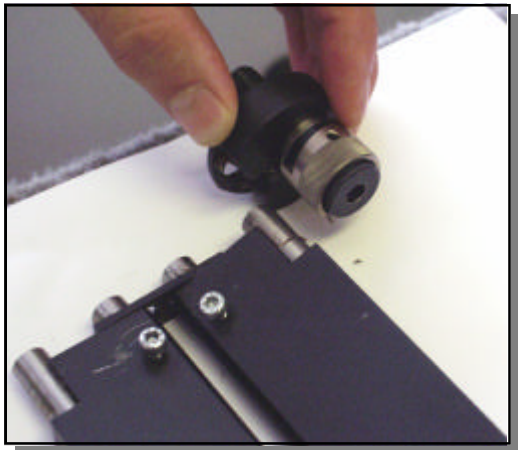
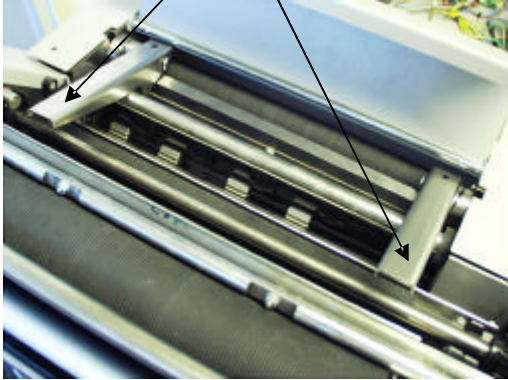

3. Using a 6mm allen key, loosen the socket head screws located inside the blade adjustment cams. Remove the screws and the blade adjustment cams.
4. Insert the blade extractor tools (70-055-01 & 70-055-02) into the holes in the adjustment links, as shown. Push downwards on the handles of the blade extractor tools to release the blade assembly from the power links.
5. Slide the blade assembly out of the creasing unit and lay it on a flat surface.
6. Slide the adjustment links away from the dowels located in the ends of the blades / anvils as shown in the photograph (left)
7. Place the new blade set into position. Check that the eccentric shoulder bolts on the link plates have been positioned as shown in fig 20.1.
8. (Upper blade / anvil only)  
Slide the adjustment links onto the dowels.

9. Slide the new blade set into the slots of the creasing unit as shown in fig. 21.1.

Locate the blade extractor tools into the holes in the adjustment links as shown. Pull the handles of the blade extractor tools upwards to engage the blade assembly back into the power links.

10. Set the cam graphics for both ends of the blade / anvil to their lowest point on the scale (ie. When the mark on the scale reaches the mark on cam holder) Fasten the socket head screws on the adjustment cams until they are tight.

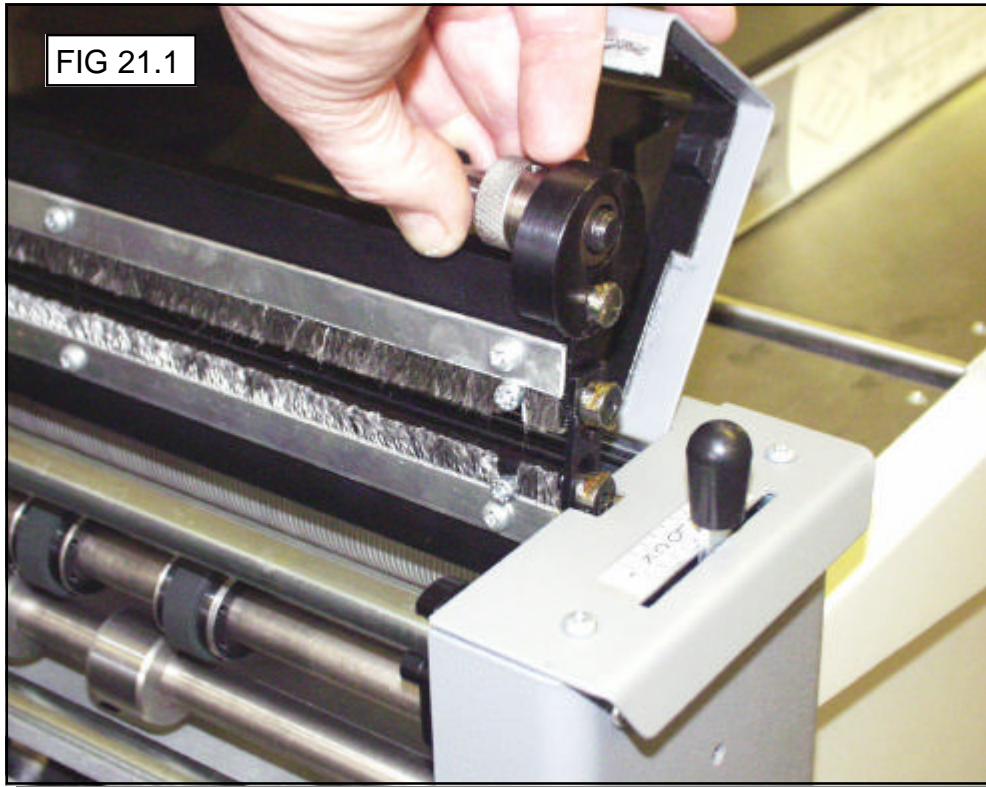

11. Push the exit guard down and replace the stacker assembly before operating the machine.
12. Switch the machine on and test the crease for form.

**If the pressure and the alignment of the crease is not to a satisfactory level, see pages 23 –25 to adjust the creasing line.**

### **‘Spares’ kits**

In the event of any damaged or lost components within the blade assembly, spares kits are available on request. However, components within the blade set can not be ordered separately ie single blade or anvil.

#### **Standard Blade set**

**Part number 76-237-02**

Consisting of a standard blade and anvil, blade brushes, blade links and alignment bolts.

#### **Narrow Blade set**

**Part number 76-237-03**

Consisting of a narrow blade and anvil, blade brushes, blade links and alignment bolts.

## **Paper crease out of square**

- Check that the sheets are all square and exactly the same size before loading the stack on to the table.
- Check that the roller tilt mechanism is correctly set and locked in position.
- Check that the adjustable side lay has been correctly positioned ie. No further than 0.5mm from the paper stack.

## **Paper jamming**

- Check that the leading edge of the paper is not being damaged by the paper gate. If this is occurring, check that the suction slot and the paper gate have been correctly set.
- Check that the first crease position is not too close to the leading edge of the paper. A minimum distance of 32mm is recommended.

## **Machine will not start**

- Check the power supply to the machine.
- Check that the emergency stop button has been released.
- Check that the exit guard is down.
- Check that the stacker unit is located correctly and has not been disconnected from the magnetic switch.
- Check that the lower blade / anvil is connecting to the home switch (mounted below the lower blade / anvil).

## **Paper not feeding**

- Check that the paper stack is not too high or too heavy for the feeder. The height of the paper stack should be defined by the weight and the size of the stock being creased.
- Ensure that the adjustable side lay is not pressed against the paper stack. However, if the clearance between the adjustable side lay and the paper stack is too great, the air supply will escape instead of blowing through the paper thus making it difficult to feed.
- Check that the clearance between the paper gate and the suction roller is not set too low.
- On digital media, the feeding performance may be improved if the leading edge of the stack is trimmed before loading onto the Autocreaser 50.

- Check that the air distribution has been correctly set.
- Check that the air separation has been set high enough to feed the sheets.
- For heavy stocks, very small or very large sheets, embossed or even irregular stock, it may be required to feed the sheets manually - see page 17 for instructions.
- Check that the gap of the infeed rollers is set correctly (see page 15).

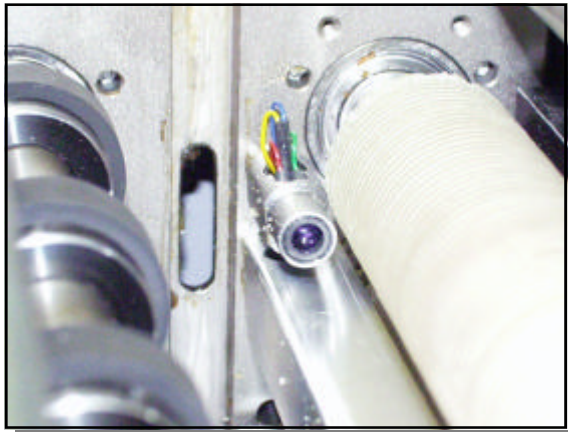

### Machine not counting

- Open the exit and remove the blade set (see pages 25-26) to access the dual sensor post located in between the drive rollers. Using a soft brush, clean the visible sensor on the end of the post. Use the brush to clean the sensors between the post and the bottom paper guide which are not visible. Photograph (left) shows the dual sensor post containing the sensors.

### No suction

- If the suction drum is not rotating, check all of the drive belts for cleanliness and splits (including the bottom in-feed roller drive belt).

### Control panel reads

#### • **Overlap - Probable Cause - Double Sheet**

If the machine is 'cutting out' and the control panel reads **Overlap - Probable Cause - Double Sheet** check that the machine is not feeding multiple sheets. If so, check that the paper gate has been correctly set.

#### • **Blade Not Home**

If at any time during the creasing process the control panel reads **Blade Not Home** it is indicating that the lower blade / anvil has not made contact with the HOME switch ie. blade still in top position. Switch the machine off and remove the blade set and ensure that the area is free from obstructions. Return the blade set to the creasing unit and switch the machine on. Operate the machine in the normal sequence, if the display continues to read **Blade Not Home** it is advised to contact a Service Engineer immediately.

#### • **The Paper Path is not clear**

If before operating the machine the display reads **The Paper Path is not clear** this indicates that there is an obstruction between the upper sensor assembly and the paper guide sensor (as shown in the above photograph). If there is no obvious obstruction in the paper path, switch the machine off and repeat the same procedure as explained above.

## **Recommended weekly Operator maintenance**

- Clean all sensors
- Clean in feed rollers and output drive hubs using the Morgana cleaning kit (Morgana cleaning kit part number – 90-018)
- Remove and clean the blade assembly
- With the blade assembly removed, clean the slots and surrounding area within the creasing unit.

## **Technician Maintenance**

It is recommended that your Morgana AutoCreaser 50 is fully serviced at least once every six months by a factory trained Service Engineer.

ITEM	PART NUMBER	QTY	DESCRIPTION
1	70-069	1	OPERATORS MANUAL - AUTOCREASER 50
2	90-018	1	ROLLER CLEANING KIT
3	650-040	1	POWER CORD CE UK C19 3Pin 16A 2.5Mtrs.
4	617-004	4	GLASS BALL - Ø20
5	403-01-030-006	12	SCREW - SOCKET CAP HEAD - M3 x 6 LG
6	409-01-040-004	1	SCREW - SKT. SET FLAT PT. - M4 x 4 LG
7	620-007	1	HEXAGON BALL DRIVER 2mm
8	620-020	1	HEXAGON BALL DRIVER 2.5mm
9	620-004	1	ALLEN KEY 4mm
10	620-026	1	BONDUS L WRENCH 4mm
11	620-028	1	BONDUS L WRENCH 3mm
12	620-033	1	BONDUS L WRENCH 6mm
13	624-018	1	DISPATCH BOX
14	70-055-01	1	BLADE EXTRACTION TOOL - OP SIDE
15	70-055-02	1	BLADE EXTRACTION TOOL - LAY SIDE
16	08-041-02	1	SLITTING ANVIL - UNDERSIZE.
17	08-066	1	SLITTER PERF BLADE 28T
18	624-017	3	SLITTER/SCORER PK - STYLE 0212/40X40X20

**WARNING.....**

**THE BLADES FOR ANVIL AND PERFORATING SETS ARE SUPPLIED AS MATCHING PAIRS AND SHOULD NOT BE MIXED OR LEFT UNPROTECTED OR SERIOUS DAMAGE MAY RESULT.**

ITEM	PART NUMBER	DESCRIPTION
1	1-99-10	PERFORATING BLADE SET 20T (Card)
2	1-99-12	PERFORATING BLADE SET 28T (Single sheets)
3	1-99-41	PERFORATING BLADE SET 56T (Fine perforations)
4	1-99-35	ANVIL SET USED WITH ABOVE BLADE SETS
5	76-237-03	BLADE SET - NARROW - AUTOCREASER 50
6	70-082	ANTI-STATIC KIT - AUTOCREASER 50
7	94-073-03	SIDELAY EXTENSION - NARROW SHEET - A/C 50

**ACCESSORIES....**

....May be obtained from your dealer and fitted to your machine using the instructions supplied, or by reading your operators manual.

**OPTIONS....**

....May also be obtained and fitted by your dealer. You should not attempt to fit options as specialist tools and knowledge are required.

PART NUMBER	DESCRIPTION
93-021	FEED BELT
93-022	DRIVE BELT - Vacuum Roller
609-011	'O' RING Ø20
609-014	'O' RING Ø15
94-028	LOCK PIN ASSEMBLY - Side Lay
75-250-01	HOSE - Exhaust
75-251-01	HOSE - Separation Air
75-252-01	HOSE - Evacuation
613-137	PLUNGER AND SPRING
613-255	SOLENOID COIL
609-013	'O' RING Ø25
613-365	EMERGENCY STOP SWITCH
652-011	SYSTEM SWITCH
652-009	COMPRESSOR SWITCH (UK)
652-011	COMPRESSOR SWITCH (USA)
144-04-03	JOYSTICK AND LEAD ASSEMBLY
75-345-01	CONTROL PCB ASSEMBLY
125-21-02	DUAL STEPPER DRIVE PCB ASSEMBLY
75-210-05	LCD DISPLAY UNIT - 4 LINE
655-011	PSU UNIT 5V/24V
655-015	PSU UNIT - SWITCH MODE - 24V
655-016	PSU UNIT - SWITCH MODE - 48V
76-230-02	PAPER GUIDE ASSEMBLY - Bottom Sensor
76-155	PAPER JAM SENSOR ASSEMBLY
76-154	UPPER SENSOR ASSEMBLY
98-013-03	ANTI-STATIC BRUSH
609-022	'O' RING Ø32
606-035	KNOB - Roller Tilt
76-109	POWER LINK BEARING
76-237-02	BLADE SET - Standard - Autocreater 50
76-042	DRIVE BELT - FEED BED
607-042	TIMING BELT 160XL
607-048	TIMING BELT TWIN GRIP - 200 DXL 050
608-019	SHOULDER BOLT
76-082	PERFORATOR - DRIVE HUB ASSEMBLY
76-083	PERFORATOR - DRIVE WHEEL



---

## PRODUCT RECYCLING & DISPOSAL

### European Union

#### Disposal Information for Commercial Users



Application of this symbol on your equipment is confirmation that you must dispose of this equipment in compliance with agreed national Procedures.

In accordance with European legislation end of life electrical and electronic equipment subject to disposal must be managed within agreed procedures.

Prior to disposal please contact your local dealer or representative for end of life take back information.

#### Disposal Information for Domestic Users



Application of this symbol on your equipment is confirmation that you should not dispose of the equipment in the normal household waste stream.

In accordance with European legislation, end of life electrical and electronic equipment subject to disposal must be segregated from household waste.

Private households within EU Member States may return used electrical and electronic equipment to designated collection facilities free of charge. Please contact your local disposal authority for information.

In some Member States when you purchase new equipment your local retailer may be required to take back your old equipment free of charge. Please ask your retailer for information.

### Other Countries

Please contact your local waste authorities and request disposal information.

