

UCHIDA

OPERATION MANUAL

Paper Folder F-45N/F-43N



Read this Operation Manual before using this machine. Keep

the Operation Manual with care in a fixed storage place so that it may be available whenever required.

UCHIDA YOKO CO., LTD.

November 22, 2001

Safety Instructions

Definition of Symbols and Notes

In this manual following names and signs stand for possible dangers.



Danger

This Symbol stands for immediate danger threatening the life and health of persons. Disregarding these instructions may cause severe damage to health and even serious injuries.



Caution

This symbol stands for an endangering situation that may occur. Disregarding these instructions may lead to slight injuries or damage to property.



Note:

This symbol stands for notes, operational hints and other useful information. They are convenient for exploiting the machine's functional abilities.

Danger	
	Make sure that the machine is electrically grounded. This prevents an electric shock when there is a leak of electricity.
	Use the machine at 110 – 120VAC, 220 – 240VAC with a frequency of 50Hz to 60Hz. A fire may start or the machine may break down if a higher or lower voltage is used, or if an electric current with a frequency that is not within the range of frequency stated above.
	Do not place any object on this machine. A fire may start or electricity may leak if water or a foreign object enters inside the machine.
	Handle the power cord with care. A fire may start or an electric shock may be caused if the cord is damaged, broken, or processed, if a heavy object is placed on the cord, or if the cord is bent forcibly.
	Do not pull the power plug out of or put it in the electric outlet using a wet hand. Otherwise, an electric shock may be caused.
	Do not remove the cover of this machine. Otherwise, an electric shock or injury may be caused.
	Do not remodel this machine. Otherwise, a fire may break out or an electric shock may be caused.
	If the machine is used when it is in an abnormal condition, such as generating heat, emitting smoke, and giving out a strange smell, a fire may break out or an electric shock may be caused. Turn off the power switch immediately and then pull the Power plug out of the electric outlet. Afterward, consult with your dealer.
	If abnormalities such as the power cord generating heat and giving out a strange smell are found, turn off the power switch immediately and then pull the power plug out of the electric outlet. Afterward, consult your dealer.
	If a foreign object enters into the machine, turn off the power switch first and then pull the power plug out of the electric outlet. Afterward, consult your dealer.
If thunder approaches, pull the power cord out of the electric outlet to prevent a fire or breakdown caused by the falling of a thunderbolt.	

Caution



Do not let hairs, a necktie, or necklace hang above the drive of the machine. Doing so may cause an injury.

Do not put the machine on an unstable place such as a shaky stand and a slant floor. Doing so may cause the machine to drop or fall down, causing an injury.

Do not put the machine in a moist or dusty place. Doing so may start a fire or cause an electric shock.

Be sure to pull out the power cord while holding the plug. If the power plug is pulled out while holding the cord, a fire may break out or an electric shock may be caused.

Be sure to pull the power plug out of the electric outlet first when moving this machine. Otherwise, the cord may be damaged, causing a fire or an electric shock.

Be sure to pull the power plug out of the electric outlet for safety purposes when this machine is not used for consecutive holidays or for other reasons.

Introduction

Thank you very much for purchasing the Paper Folder F-45N/F-43N. This machine enables users to achieve greater efficiency in clerical work by releasing them from paper-folding work that has manually been performed in the past. Please read this Operation Manual carefully before using this machine.

This Operation Manual is good for both F-45N/F-43N.

The explanation for functions of F-43N is mentioned using *italic type* letters.

Contents

Safety Instructions	1
Introduction	3
Contents	3
(1) Specifications	4
(2) Accessories	5
(3) Part Name	6
(4) Designation and Functions of Operation Panel	7
(5) Indication of the Counter	8
(A) Addition Counter	8
(B) Subtraction Counter	8
(6) Preparation	9
(7) How to Use	11
(A) Standard Folding of Standard-size Paper	11
(B) Standard Folding of Non-Standard-size Paper	13
(C) Cross Folding	15
(8) Adjustment	16
(A) Slant Adjustment	16





(B) Fine Adjustment.....	16
Fine Adjustment for Table 1.....	17
Fine Adjustment for Table 2.....	18
(9) Storage.....	19
(A) Storage.....	19
(B) Cancellation of storage	20
(C) Cancellation of total storage	21

(1) Specifications

Model:	F-45N/F-43N
Paper sizes:	B7 size (91 × 128mm) to A3 size (297 × 420mm) B7 size is single only, B6 size must not available for fold gate.
Paper weight:	45 to 160g/m ² (up to 230g/m ² for single fold)
Paper quality:	Woody paper, high-quality paper, high-quality paper for stencil printing, medium-quality paper
Fold types:	Single, gate, letter, zigzag, double parallel, and fold-out. In addition, irregular folding and cross folding using double folding can be performed.
Fold dimensions:	Maximum fold dimensions Table 1: 330mm (zigzag, double parallel, and fold-out) Table 2: 214mm (single, gate, and letter)
	Minimum fold dimensions Table 1: 50mm (gate and letter) Table 2: 40mm (single, zigzag, double parallel, and fold-out)
Paper feed system:	Three-roller friction feed system
Maximum stacking:	500 sheets (64kg/m ² of high-quality paper)
Folding speed:	3,300 to 10,080 sheets per hour (single fold using A4 size paper)
Control system:	Automatic setting by built-in microcomputer (digital 10 key input)
Additional functions:	Skew adjustment memory, paper jam detector, four-digit counter with addition/subtraction modes, and automatic paper size detector (A3, B4, A4, A5, B6 and B5 sizes) Storing special fold data for outer norm paper: three kinds (F-45N only) Paper ejection roller position selective automatically in 3 steps (F-45N only, F-43N manually) Paper feed table: auto elevation function (F-45N only) Auxiliary paper guide for cross fold A perforator can be installed (optional)
Noise:	80dB
Power consumption:	75W
Power used:	110 - 120 VAC, 220 – 240 VAC 50 and 60Hz
Dimensions:	870 × 530 × 520mm (during use) 660 × 530 × 520mm (while in storage)
Net weight:	33.5kg
Option:	Perforator table assembly with a 2-mm or 4-mm perforation cutter

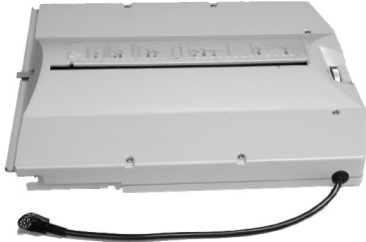
(2) Accessories

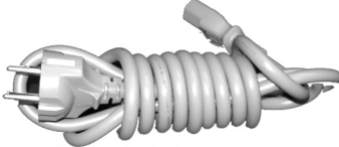
Make sure that the following accessories are included in the package after opening it. Contact your dealer immediately if there are missing accessories.

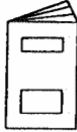
Accessories	Number	Figure
Table 1	1	
Table 2	1	
Power cord	1	
Paper support auxiliary paper feed guide, right and left	Right 1 Left 1	
Machine cover	1	
Operation Manual	1	

(3) Part Name

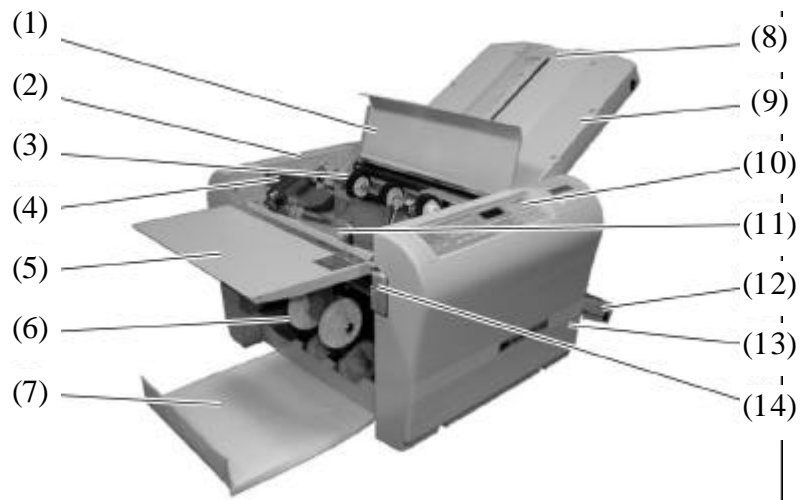

Number	Name	Number	Name
(1)	Roller cover	(11)	Paper feed table
(2)	Left side cover	(12)	Table 2
(3)	Paper feed roller	(13)	Right side cover
(4)	Paper guide	(14)	Paper feed table lever (F-43N only)
(5)	Auxiliary feed table	(15)	Table 1 socket
(6)	Paper ejection roller	(16)	Table 2 socket
(7)	Paper ejection table	(17)	Power switch
(8)	Stopper fine adjustment knob	(18)	Inlet

(9)	Table 1	(19)	Circuit breaker
(10)	Control panel		

(4) Designation and Functions of Operation Panel

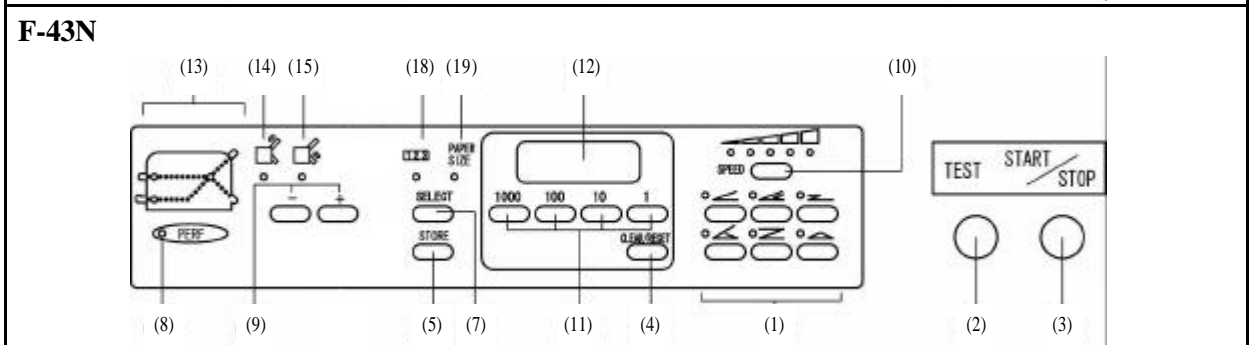
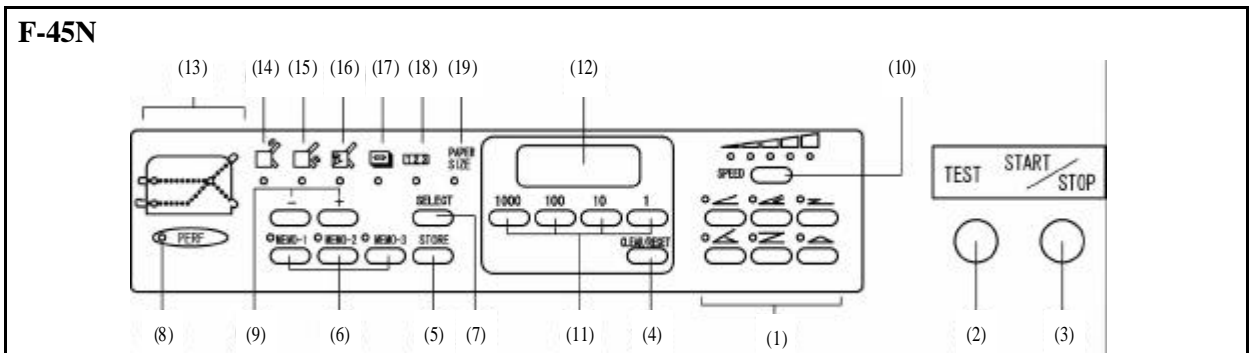

No.	Designation/Indication	Function
(1)	Fold type key	Six folding types can be input and stored.
(2)	Test key	Test folds two sheets without counting.
(3)	Start/Stop key	Starts and stops the machine.
(4)	Clear/Reset key	Clears counter indication and resets error.
(5)	Store key	Fold position after adjustment is stored.
(6)	Memory 1/2/3 key	Three special folding types are stored. (only for F-45N)
(7)	Select key	Used for selecting the indication of the counter, the position of the stopper stud of Table 1 and 2, the position of paper ejection roller, paper length.
(8)	Perforation mode lamp	It lights when the optional sewing unit is installed.
(9)	+/-key	Used for adjusting the position of the stopper of Table 1 and 2, the position of paper ejection roller, paper length
(10)	Speed adjustment key	Used for adjusting the speed.
(11)	Numerical key	Used for inputting the reduced number for subtraction counting and the length of non-standard-size paper
(12)	Counter	Shows the number of sheets, the position of the stopper pin of Table 1 and 2, and paper size.
(13)	Check lamp	It lights when paper stock runs short, or indicates the location where paper feed trouble occurs.
(14)	Table 1 stopper move mode lamp	It lights when the position of stopper of Table 1 is adjusted.
(15)	Table 2 stopper move mode lamp	It lights when the position of stopper of Table 2 is adjusted.
(16)	Paper ejection roller move lamp	It lights when the position of the paper ejection roller is adjusted (only for F-45N).
(17)	Paper length input mode lamp	It is on when paper length is input (only for F-45N).
(18)	Counter input mode lamp	It lights when reduction is indicated on the counter.
(19)	Paper size input mode lamp	It lights when paper size is indicated.

(5) Indication of the Counter

(A) Addition Counter

The number indicated on the counter increases by one each time a sheet of paper is folded.

Press the Select key and select the Counter Input Mode Lamp

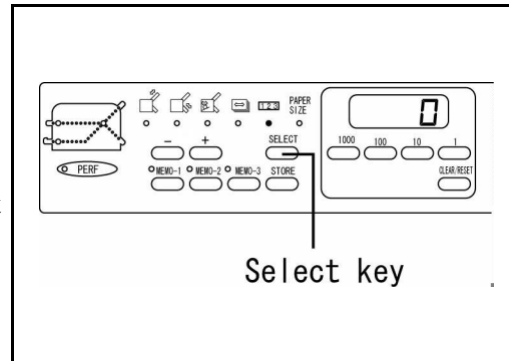

Press the Clear/Reset key and reset the number at zero (0).

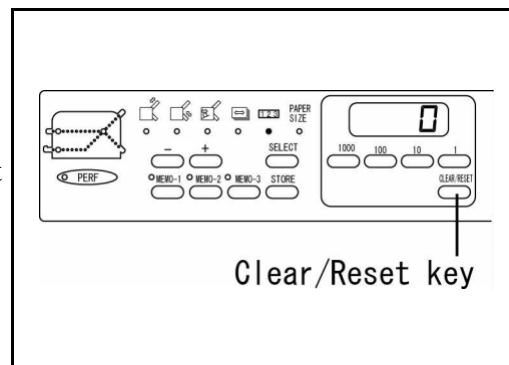

(B) Subtraction Counter

The number indicated on the counter decrease by one each time a sheet of paper is folded.

Press the Select key and select the Counter Input Mode Lamp.

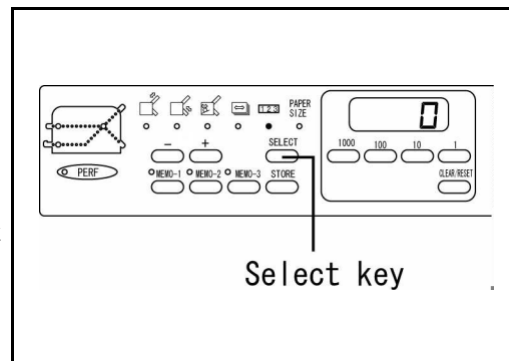

Input the desired number using the Numerical keys.(20 is input in this case)

Subtraction Mode Lamp will light.

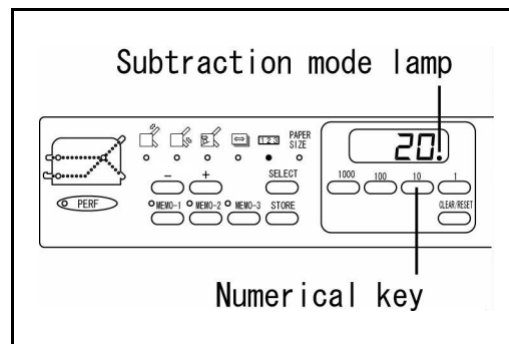

(6) Preparation

Install Table 1 and 2 at the machine.

Insert the front notched part of Table 1 into the stud (1) of the machine and drop its rear notched part on the stud. (2). Insert the plug into the connector (3).

Caution:

The connector has its direction.
Insertion by force may cause trouble.

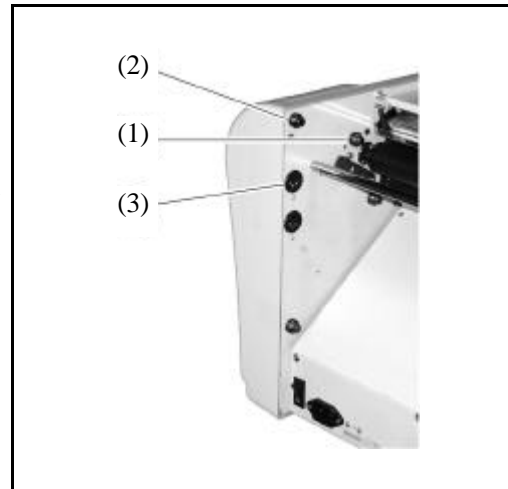

Insert the front notched part of Table 2 into the stud (4) of the machine and drop its rear notched part on the stud (5). Insert the plug into the connector (6).

Caution:

The connector has its direction.
Insertion by force may cause trouble.

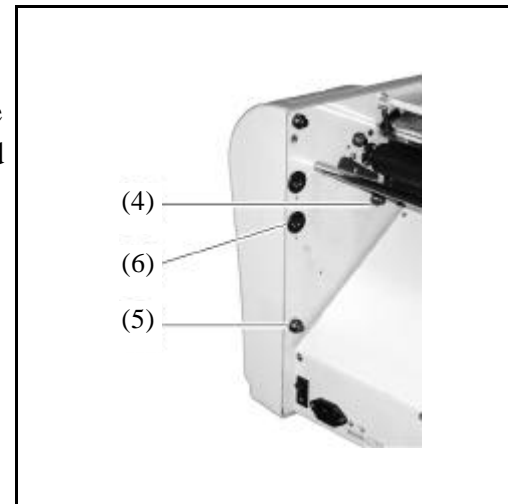

Pulling the paper stacking table out and set it while lifting the auxiliary table.

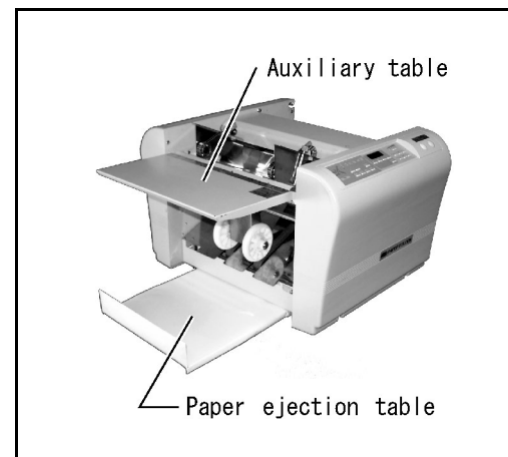

Insert the power cord into the outlet.

Caution:

Be sure to undo before use.

Do not use any power cord other than provided as an accessory.

The shape of outlet differs according to the country.

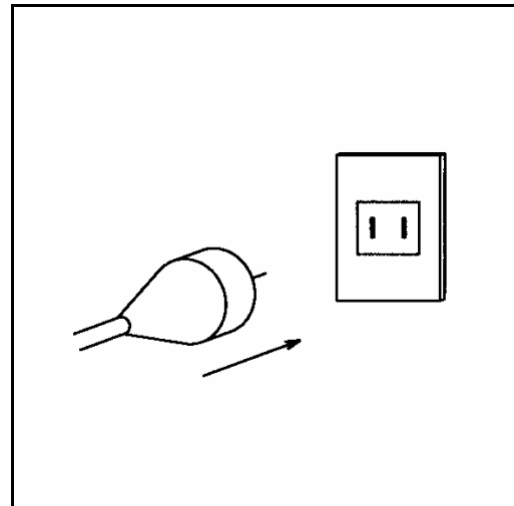

Insert the power cord into the inlet.

When the power switch is on, the stoppers of Table 1 and 2 move to the origin.

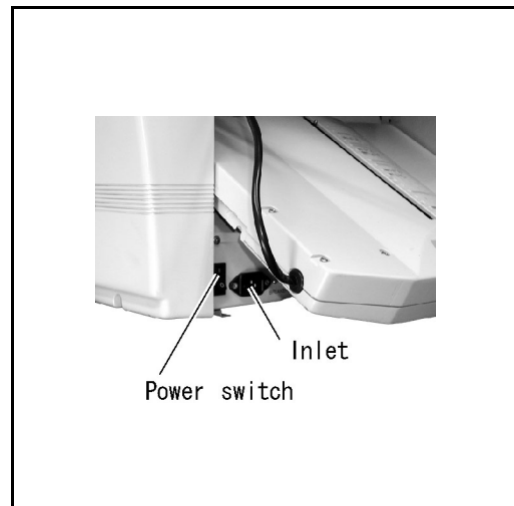

(7) How to Use

(A) Standard Folding of Standard-size Paper

? F-45N

How to perform standard folding of standard-paper

✦ After the power switch is on...

Set the standard-size paper. Loosen the paper guide setscrew and set the paper guide to fit the width of the paper.

Stack the paper on the paper feed table with its printed side facing up (its printed side down in case of fold-out) after neatly arranging it.

Make the paper guide closely contact the paper, and tighten the setscrew.

<to next page>

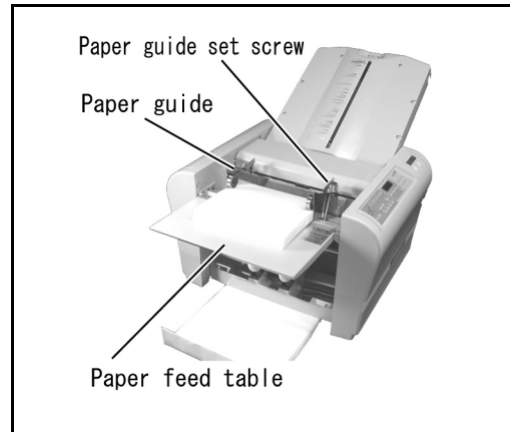

? F-43N

How to perform standard folding of standard-paper

✦ After the power is on...

Raise the paper feed table lever.

Set the standard-size paper. Loosen the paper guide setscrew and set the paper guide to fit the width of the paper.

Stack the paper on the paper feed table with its printed side facing up (its printed side down in case of fold-out) after neatly arranging it.

Make the paper guide closely contact the paper, and tighten the setscrew.

Lower the paper feed table lever.

<to next page>

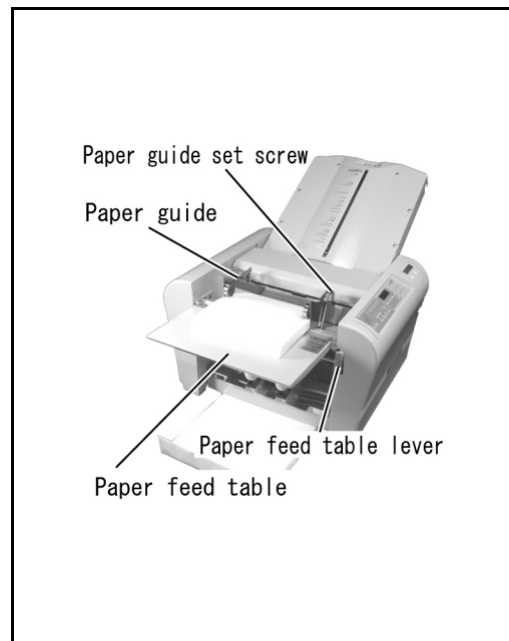

Setting the paper ejection roller (F-43N only):

Move the paper ejection roller to the position that fits the size of paper being used.

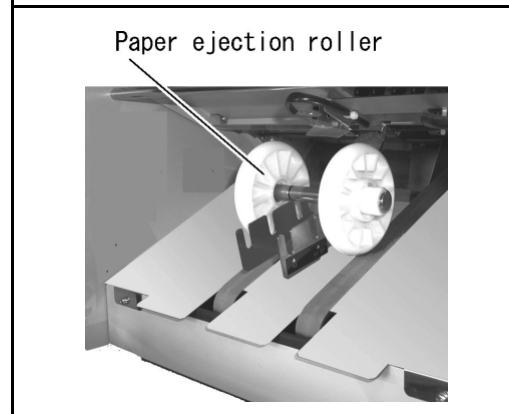

Selecting of folding type:

One of the six folding types (Single, Gate, Letter, Zigzag, Double, Parallel Fold-out) can be selected. Press the desired folding type key.

Example: Single folding using A3 size paper.

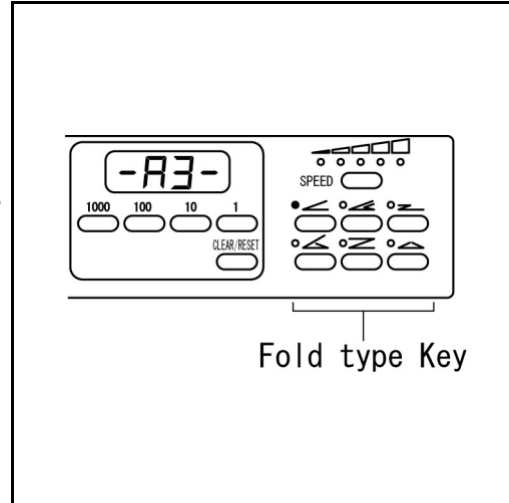

Test folding:

If the Test key is pressed, two sheets will be folded without counting.

Check if the second sheet of paper has been folded correctly.

(In case of correcting slanting folding)

Refer to Slant Adjustment on page 17.

Caution:

(In case the stopper fine adjustment knob is moved) When the Test key is pressed, the machine will continue folding, and when the Start/Stop key is pressed, the machine will start to fold after the stopper is returned to the previous position.

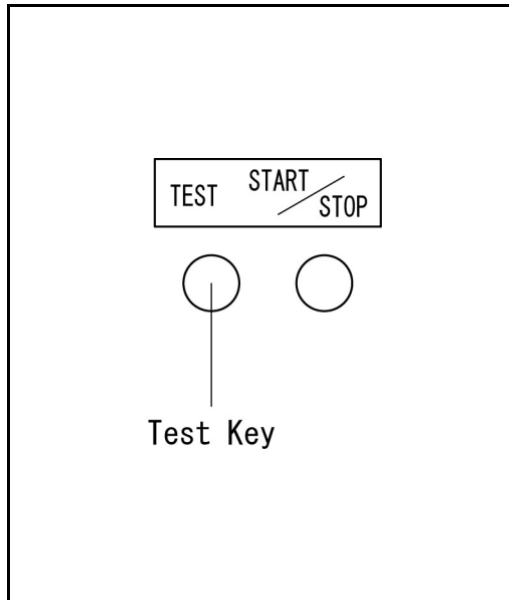

Continuous folding:

When the Start/Stop key is pressed, the machine will continuously fold the paper. When the Start/Stop key is pressed while the machine is in operation, the machine will stop the operation, but addition on the counter will continue. If you wish to fold only the number of sheet desired, refer to subtraction counter function.

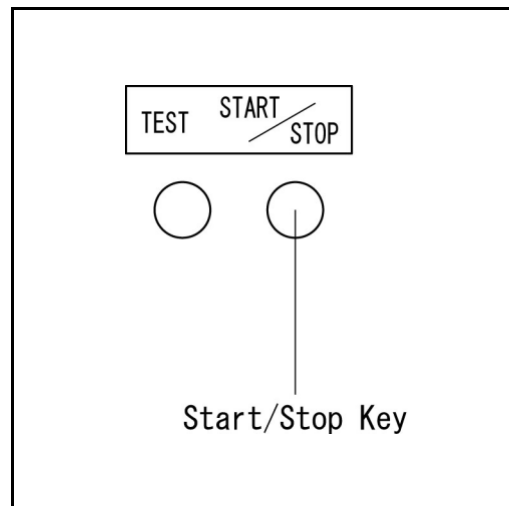

(B) Standard Folding of Non-standard-size Paper

Measure the paper length.

The arrow indicates the direction of paper feeding.

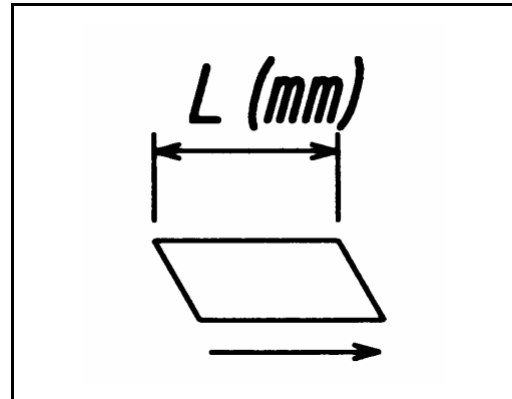

Press the Select key and select the Paper Length Input Mode.

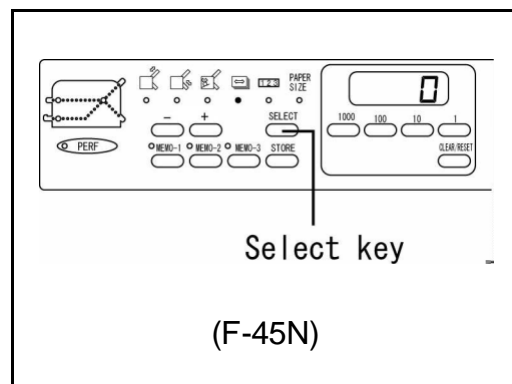

(F-45N)

Input the paper length using the Numerical keys.

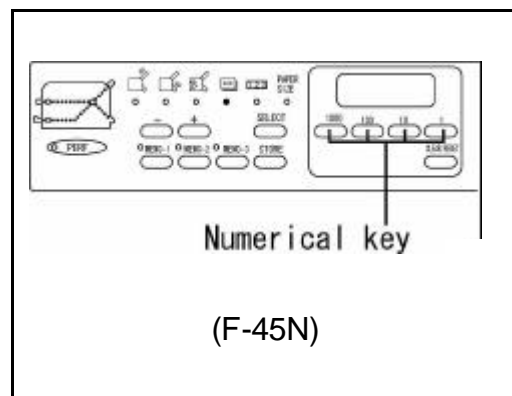

(F-45N)

Setting the paper ejection roller.

? F-45N

Select the paper ejection roller move mode using the Select key.

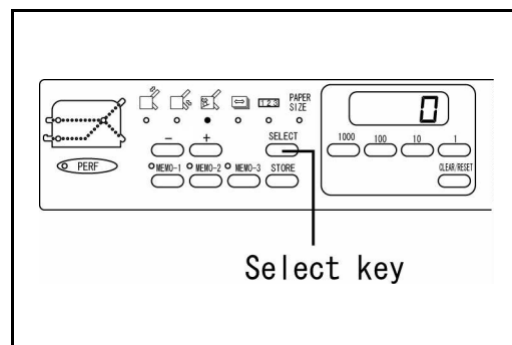

Set the designated position using the +/- key.

Indication	1	2	3
	Standard-size paper	A3	B4, A4
Non-standard-size paper	Setting the designated position		

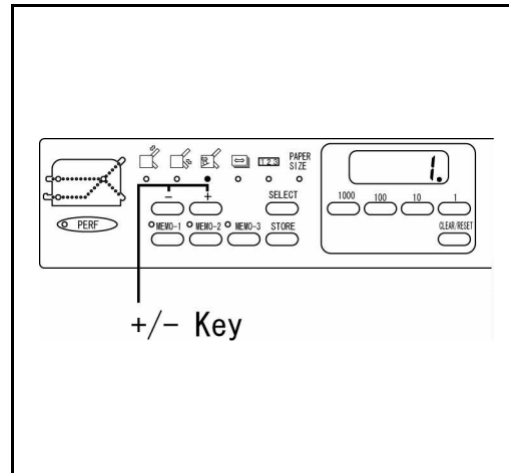

Setting the paper ejection roller:

? F-43N

It moves to the position to fit the paper size.

Advice

Concerning positioning of the paper size and the paper ejection roller, refer to “Roller position indication” seal. If ejection is not performed properly, set at a different position.

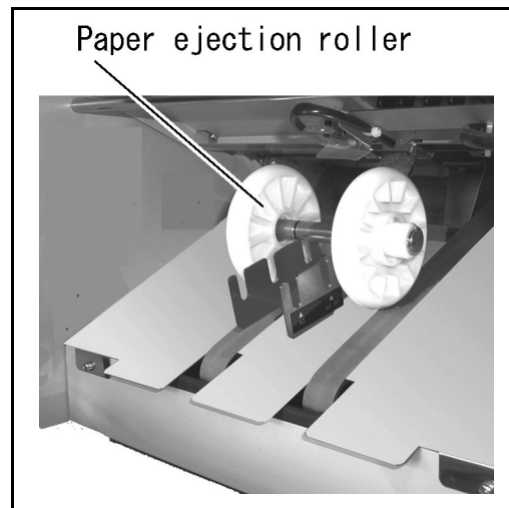

Note:

Calculate the position of the table 1 and table 2 stopper in relation to the measurement value L.

(Example) In the case of performing the zigzag fold using sheets of paper 300mm in length:

Table 1 = $300 \times (2 / 3) = 200\text{mm}$

Table 2 = $300 \times (1 / 3) = 100\text{mm}$

	Table 1	Table 2
SINGLE	Original position	1/2
GATE	1/4	1/2
LETTER	1/3	1/3
ZIGZAG	2/3	1/3
DOUBLE	1/2	1/4
PARALLEL FOLD-OUT	3/4	1/4

(C) Cross Folding

Cross folding refers to performing the double parallel, letter, or other types of folds for the sheets of paper folded using the single folding method.

Cross folding can be used if, for example, the sheet of A3-size paper folded using the double parallel folding method is still too large to be enclosed in envelope.

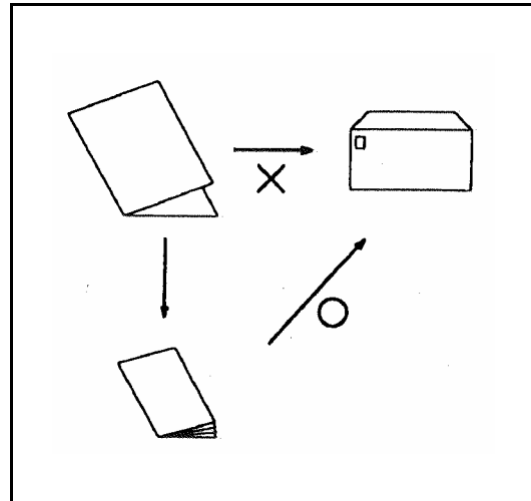

Note:

The maximum weight of paper that can be used for cross folding is 105g/m^2 .

This requirement, however, varies according to the following conditions:

- Paper type; Paper size;
- Whether grains run lengthways or sideways;
- Temperature and relative humidity;
- Printing condition.

The folding position may be displaced to a greater extent than when the paper is folded using a regular fold method, or a corner of the folded paper may be folded inside as indicated in the figure. These, however, do not mean that the machine has broken down.

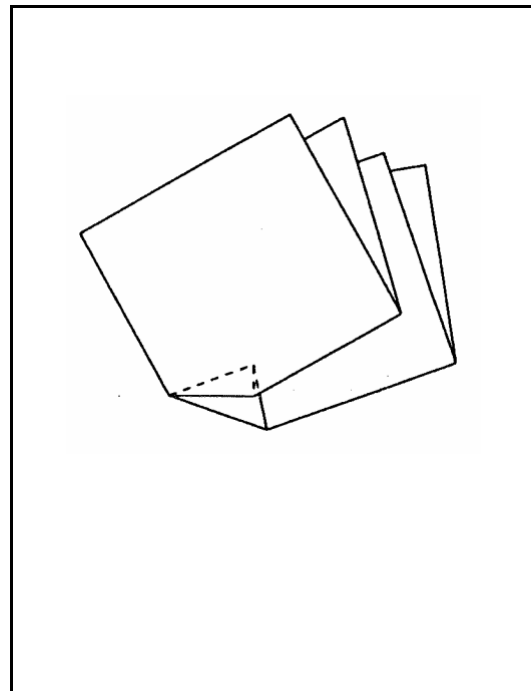

Note:

Press the crease hard using the hand. Do not stack too many sheets of paper on the paper feed table.

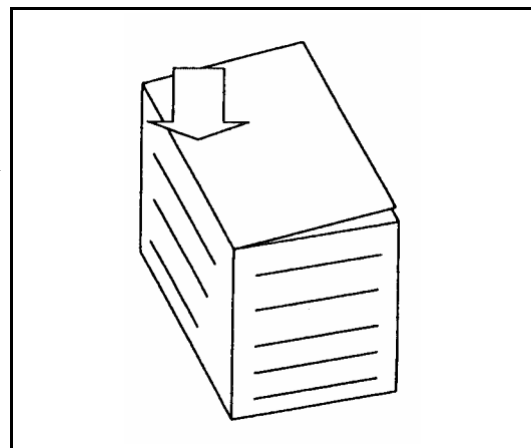

(8) Adjustment

(A) Slant Adjustment

If the folding position is slanted because the edges of the paper are slanted or for other reasons, it can be adjusted using the slant adjustment knob.

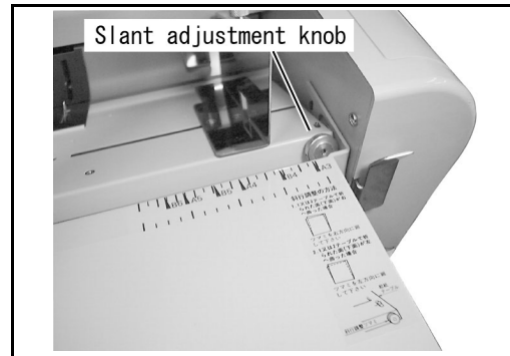

(B) Fine Adjustment

Move the stopper using the stopper fine adjustment knob.

Caution: (In case the stopper fine adjustment knob is moved) When the Test key is pressed, the machine will continue to fold, and when the Start/Stop key is pressed, the machine will start to fold after the stopper is returned to the previous position



Note:

When the stopper is moved largely, it will be convenient to use the +/- key.

In case of Table 1

Press the Select key and select the Table 1 Stopper Move Mode.

Press the +/- key and move the stopper to the desired position.

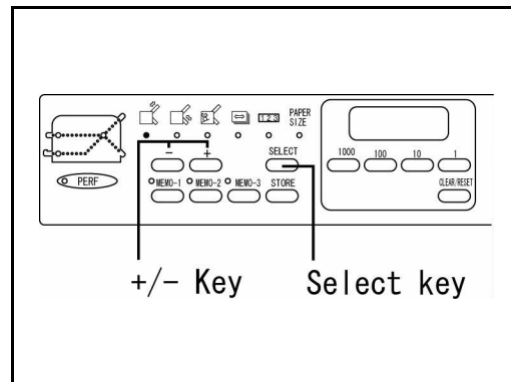







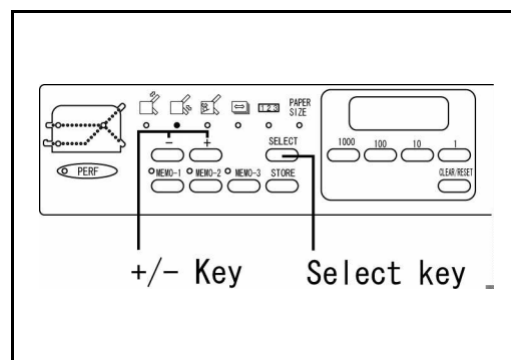







In case of table 2

Press the Select key and select the Table 2 Stopper Move Mode.













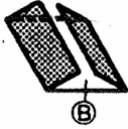

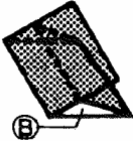
Press the +/- key and move the stopper to the desired position.



Fine Adjustment for Table 1

Fold type		Plane (A)	Direction to turn the Table 1 fine adjustment knob
Single folding	Table 1 is not used		
Gate folding		Long	
		Short	
Letter folding		Long	
		Short	
Zigzag folding		Long	
		Short	
Double parallel folding		Long	
		Short	
Fold-out folding		Long	
		Short	

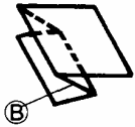
Fine Adjustment for Table 2

Fold type		Plane (B)	Direction to turn the Table 2 fine adjustment knob
Single folding		Long	
		Short	
Gate folding		Long	
		Short	
Letter folding		Long	
		Short	
Zigzag folding		Long	
		Short	
Double parallel folding		Long	
		Short	
Fold-out folding		Long	
		Short	

(9) Storage

(A) Storage

? F-45N

Storage of folding result can be input in the Memory 1/2/3 key and the Fold type key.

What can be stored is the positions of the Table 1 and 2 stoppers, the position of the paper ejection roller and folding speed.

The conditions in which desired folding can be performed should be prepared for in advance.

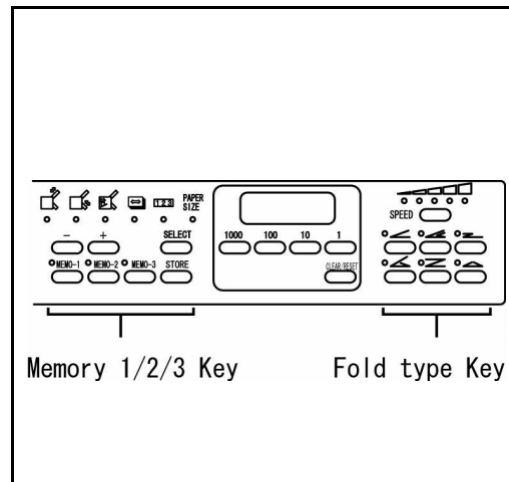

? F-43N

Storage of folding result can be input in the Fold type key.

What can be stored is the position of the Table 1 and 2 stoppers and folding speed.

The conditions in which desired folding can be performed should be prepared for in advance.

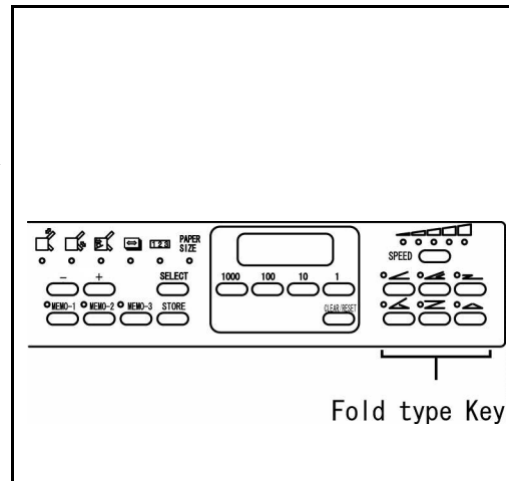

Select the key in which the storage will be input. Keep pressing the Store key and release immediately when the alarm rings once.

The lamp of the key in which the storage has been input will flash.

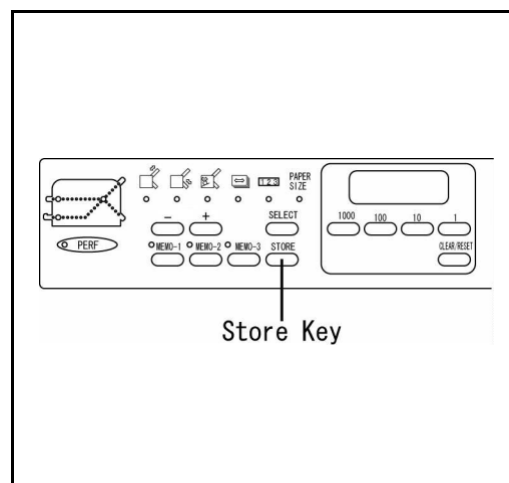

(B) Cancellation of storage

Cancel the storage input in the key.

Point:

The machine will be enabled to perform standard folding set by the manufacturer.

Select the key in which the storage is to be cancelled.

Point:

The lamp of the key in which the storage is input flashes.

Keep pressing the Clear/Reset key and release immediately when the alarm rings once.

The lamp of the key in which the storage has been cancelled will light.

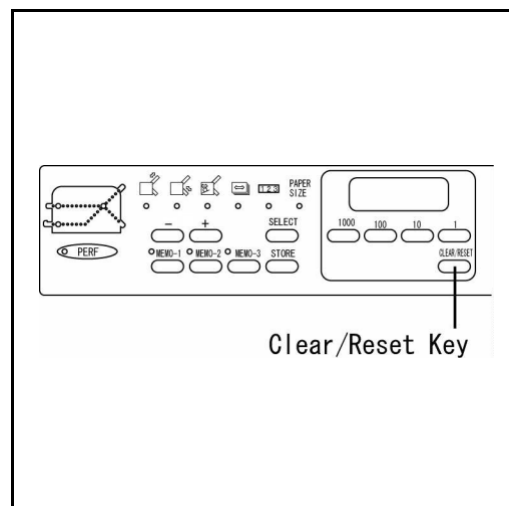

Note:

Folding position for the outer norm paper can also be stored on 'Fold type' keys up to 6 patterns in the same way as the procedure for storing the normal size paper such like A-3, A-4, A-5, B-4, B-5 and B6 size.

(C) Cancellation of total storage

Cancel all storage input in all the keys.

Point:

The machine will be enabled to perform standard folding set by the manufacturer.

Keep pressing the Clear/Reset key and release immediately when the alarm rings twice.

The lamp of the key of which the storage has been cancelled will light.

